

OPERATING INSTRUCTIONS D6-D280

**OPERATING INSTRUCTIONS
Diesel Hammers
D6-D280**



office (936)494-4200
1-800-409-0018
fax (936)494-4517
www.Pileco.com
491 Conroe Park W. Dr.
Conroe, TX 77303

5/14/2025

Ceo Introduction	4
Safety Agreement	5
Diagram of a Hammer	6
Safety Indicators	7
Chapter 1 Safety Guidelines	8-14
Proper Use of the Diesel Pile Hammer	9
Safety Handling of Diesel Pile Hammer	10
Safety info for Hammer Operator	11
Safety info for Excavator Operator	12
Safety Info for Operator and Foreman	13
Safety Info for Diesel Hammer Mechanic	14
Chapter 2 Conversion Charts	15-17
Chapter 3 Technical Data	18-25
Diesel Hammer D6-D50 Data	19
Diesel Hammer D62-D280 Data	20
Diesel Hammer Pump Settings D6-D125	21
Diesel Hammer Pump Settings D138-D280	22
Pump Settings to Stroke Range	23
Sound Emission Data	24
Exhaust Emission Data	25
Chapter 4 Transport	26-29
Transport of the Diesel Hammer	27
Lifting Cables and Ground Support	28
Securing the Diesel Hammer for Transport	29
Chapter 5 Assembly & Mode of Operation	30-38
Components of Diesel Hammer	31
Section View Diesel Hammer	32
Operating Principles	33
Pile Driving Equipment	34
U Type Lead Systems	35
Conversion for Driving Batter Piles	36
Cylinder Extensions	37
Safety Devices	38
Chapter 6 Starting Diesel Hammer	39-54

Filling of Fuel and Lube Tank	40
Filling of Lubricant Lines w/oil	41
Fuel Pump Priming	42
Assembly of Pile Helmet Cushions	43
Guiding for the Pile Helmet	44
Lifting of Piles	45
Hammer and Helmet in Operating Position	46
Placing Hammer in Fixed Lead-Vertical	47-48
Tripping Device	49-50
Control of Fuel Supply	51-52
Cleaning of Combustion Chamber	52-53
Start and Control	53-54
Chapter 7 Operation	55-63
General Info-Refusal	56-57
Blow Energy	58
Hydraulic Controlled Fuel Pump	59
Offshore Lead w/Bridle Bar	60-61
Starting Hammer w/Hydraulic Cylinder	61-62
Hydraulic Starting Device and Power Pack	63
Chapter 8 Shutting Down & Storage	64-67
Shutting Down and Storage/Removal From Lead	65-67
Chapter 9 Maintenance (daily, weekly and monthly)	68-70
Chapter 10 Service & Troubleshooting	71-89
Service & Troubleshooting	72-74
Guides	75
Tripping Device	76-77
Pumps	78-79
Filter	80
Catch Groove & Piston Catch Ring	81-83
Piston & Impact Block Rings	83-87
Compression	88
Chapter 11 Applicable Fuel & Lubrication	90-91
Chapter 12 Summaries & Calculation Aids	92-94
Chapter 13 General Bolt Torque	95-97
Inspection Protocol	99-111

Dear Valued Customers,

Pileco Inc. in our continued search for SMARTER PILE DRIVING PERFORMANCE coupled with its 50-year history and with today's technologies are here to provide you with exceptional service, rentals, and technical support with a superior fleet of products. Those products include pile driving equipment, diesel hammers, hydraulic hammers, vibratory hammers, power units, lead systems and parts. We are always looking to the future, looking to bring you innovation, continued quality and affordability.

So thank you for choosing us as your Diesel Hammer and Foundation Equipment Dealer. Here at Pileco Inc. we appreciate your business and continually strive to provide excellent service and quality products. We are always interested in hearing from you on how we can make your lives easier. So please contact us with any questions or concerns.

PILECO
Sincerely,
George Smith, CEO



Before Operating Read....

All operating and safety instructions must be read in full before proceeding with hammer assembly and use.

1. Operators shall be provided operating manuals at the time of purchase or rental. This manual includes proper procedures for: Assembly, Transport, Safety, and Operation of diesel pile hammers.

2. Individuals shall be required to provide documentation that all procedures and safety regulations have been read and understood by all working on or around diesel pile hammers. To include assemblers, operators, transporters, maintenance, and repair individuals or crews.

Pileco, Inc. shall not accept any liability if operating instructions have been used improperly or disregarded.

Sign and Date:

I have read and understand any and all sections pertinent to procedure and safety instructions pertaining to my job description in the assembly, transport, operation, disassembly, maintenance and or repairs to diesel pile hammer and accessory equipment.

Sign: _____ Date: _____

office (936)494-4200
1-800-409-0018
fax (936)494-4517
www.Pileco.com
491 Conroe Park W. Dr.
Conroe, TX 77303

Diesel Pile Hammer Components

The picture below should help to familiarize you with the diesel hammer components.

Please refer back to this diagram at any time.

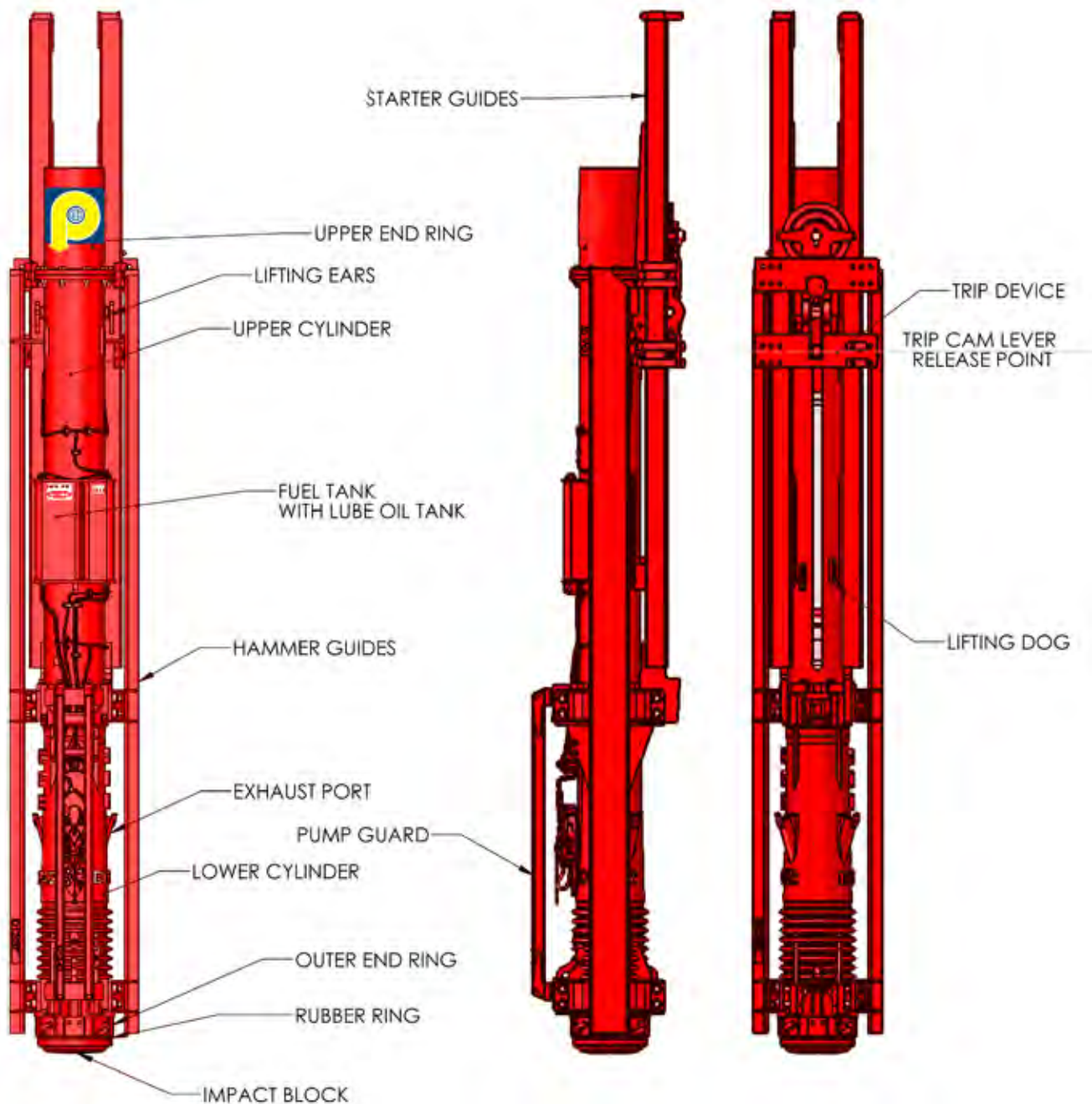
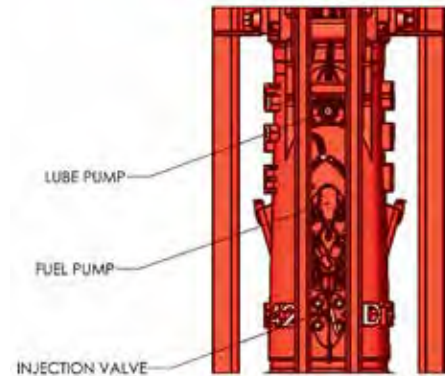

Safety Indicators Explained

The following symbols are used throughout the manual.

Caution indicates a potentially hazardous situation which, if not avoided may result in minor or moderate injury. For example, protect eyes!



CAUTION

Warning indicates a potentially hazardous situation which, if not avoided could result in death or serious injury.



!WARNING!

Danger indicates an imminently hazardous situation, which if not avoided will result in death or serious injury.



!DANGER!

Chapter 1

Safety Guidelines



Proper & Improper Use of the Diesel Pile Hammer

Diesel Hammers are to be used for driving suitable piling into soil that is properly tested and approved for piling.

Any other use of Diesel Piling Hammer may result in serious injury or death.

! D A N G E R !

LIFT HAMMER WITH TRIP GEAR AGAINST THE LIFTING DOGS ONLY AS DESCRIBED IN OPERATING MANUAL. DO NOT LIFT TRIP GEAR AGAINST TOP OF THE STARTER GUIDES.

! W A R N I N G !

“WARNING: DO NOT LET TRIP REST ON THE LIFTING DOGS WHILE HAMMER IS OPERATING”! NEVER PLACE ANY PART OF THE BODY UNDERNEATH THE HAMMER. ALWAYS SECURE HAMMER BEFORE MOVING LEADS.

Attach warning notice supplied with hammer in good visible position on piling rig.

Safety Handling of Diesel Pile Hammer

Hammer operation shall only be performed by properly trained and qualified diesel pile hammer operators.

Be observant to issues that may arise during the operation of hammers. To prevent unforeseen problems.

Please keep operation manual in safe, dry location that may be found easily. Operators must be notified of its location and provided when requested.

Inspection of hammer shall be performed prior to initial operation of hammer. Following inspections shall be performed every year there after. Inspections shall be performed by a **qualified Diesel Pile Hammer Inspector**.

Any repairs to hammer shall be followed by inspection before hammer may be put back to use. All repairs shall be performed by **Pileco, Inc. or authorized repair mechanic**. All repairs and service shall be documented in writing and filed for retrieval upon request at a later date.

! D A N G E R !

Jobsite Conditions

- > **Weather**
- > **Soil**
- > **Overhead Power Lines**
- > **Proper Visibility (night)**

Weather conditions may change unexpectedly and rapidly. Lightening may cause a potentially dangerous and life threatening situation. ***If Lightening is present, job shall be stopped until danger has passed.***



Heavy rains may change soil condition. Therefore creating unstable ground. Secure all equipment in the area to a safe place from erosion and flooding. Hammer may shift causing further damage to site. Equipment shall be stored on flat stable ground.

Overhead power lines pose an **extreme hazard**, thus shall be **avoided**. If lines cannot be avoided, extreme caution should be maintained at all times, as well as the use of a **visual spotter** for the crane operator.

Proper visibility shall be maintained at all times. In the event of working after dark, proper lighting shall be maintained in work area. All working equipment is clearly visible so proper monitoring of hammer may occur. Also, transportation of diesel pile hammer after dark shall follow same guidelines of illumination— **beware** load shift may occur during transport. **Visibility when loading and unloading** diesel pile hammer is key to making sure there is no unforeseen damage to hammer or harm to personnel.

!WARNING!

Safety information for the Hammer Operator

Hard hat, leather work gloves, steel toe boots, reflective clothing, safety glasses and ear protection shall be worn at all times when hammer is running.

Pay close attention to proper hearing protection, as impact related frequencies may cause severe and irreparable hearing loss. (See Chapter 3, on Sound Emission)

Locate jobsite fire extinguishers as fuel mixture and fluids used to operate hammer are flammable. **Observe all no smoking signs on or around flammable items.**

While running hammer, the exhaust from burning fuel and lubricants are dangerous to breath. Make sure area is well ventilated!

Hammer safety and BURN DANGER. Hammer becomes heated during operation. Hammer will need to cool and be shut down before any work or contact with hammer. Pay special attention to impact block and exhaust ports for they become dangerously heated. **Caution Severe Burns upon contact!**

Be aware, working equipment may become loose and fall from diesel pile hammer, lead impact head, pile guiding system or the pile itself.

Always keep a good length of 15 feet (4.5 meters) away from an operating diesel pile hammer. Only the excavator/crane operator, and the jobsite foreman in charge of the pile-driving, shall maintain movement within an area of 1.5 times the lead height or the height of the excavator/crane.

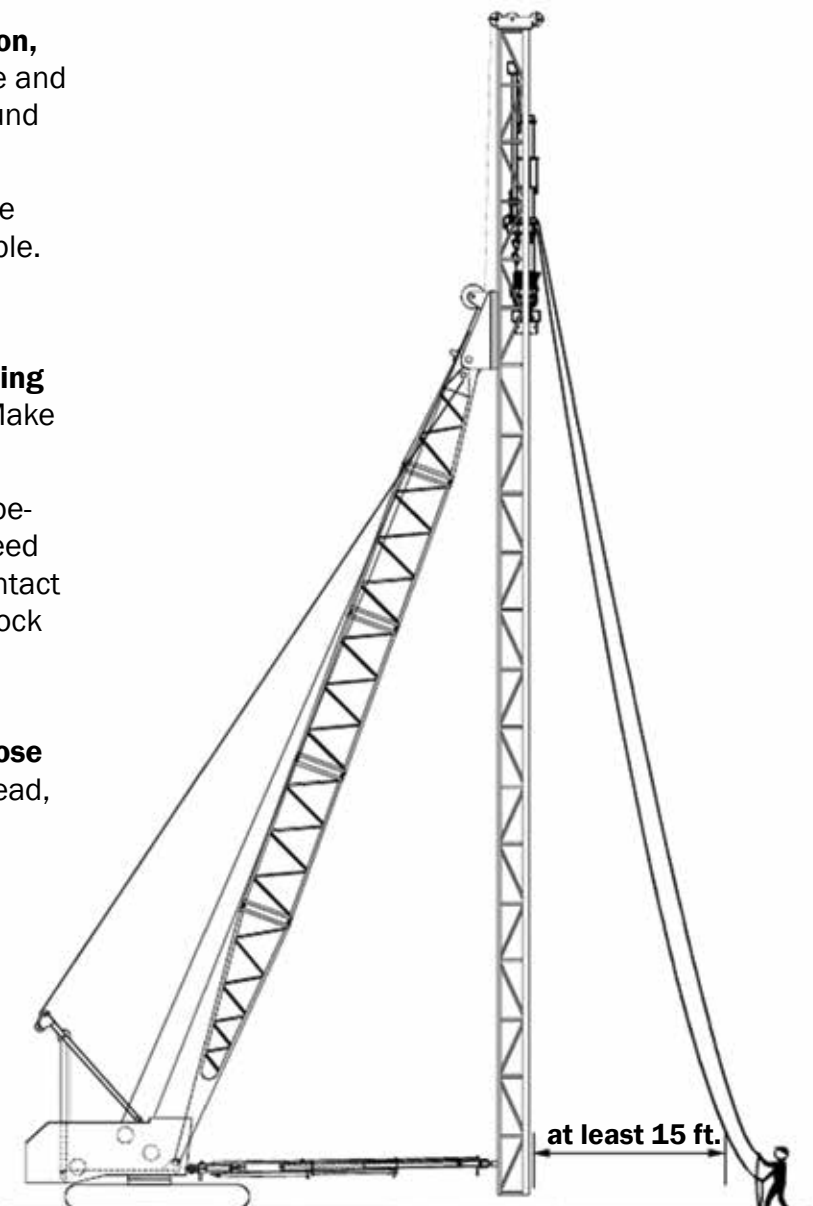

!WARNING!

Safety information for the Excavator Operator

Use only excavators/leads/cranes that exhibit a sufficient load capacity for the diesel pile hammer, pile helmet and the piles.

Make sure the accessories are safely stored away prior to lifting the equipment. Secure all loose components. Keep the load as close as possible to the ground during vertical lift. **Drive very carefully on a rocky or slippery ground or on a slope!**

You must personally make sure that no one will be placed into a dangerous situation with the moving of the equipment. Seek the assistance of a helper. Accept signals from one person only. No co-driver, please.

Observe traffic signs and rules when driving on public traffic areas.

Do not hold on to the steering wheel column, control console or operating levers when entering or leaving the vehicle. **This may cause accidental motions! Danger of accidents!**

Do not leave hammer suspended when not in use!

Swinging leads, hammer and lead sets shall be placed on ground between jobs and when not in use.

All other leads, hammer shall remain with anvil or drive cap on ground when not in use. To avoid tipping when not monitored.

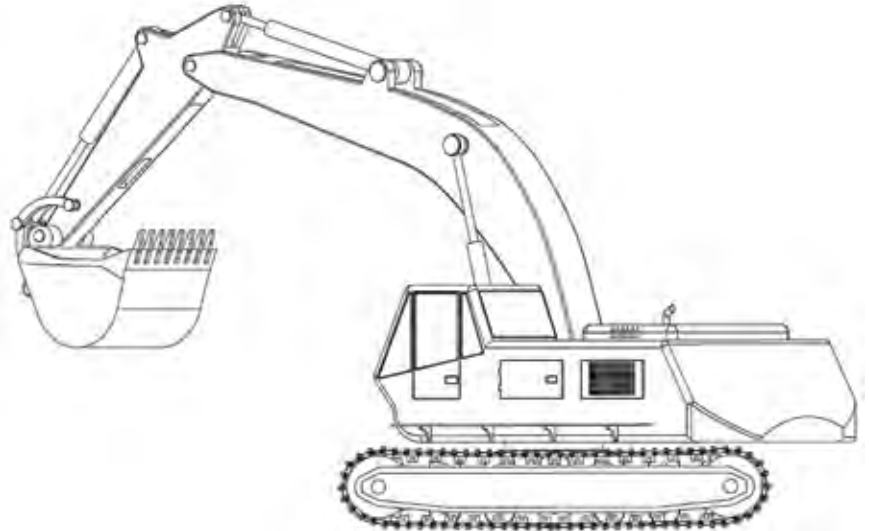

Always work up or down a slope and not laterally to the slope. Prevent any actions that could cause the equipment to overturn. When the equipment nevertheless begins to overturn or slide laterally, it will be necessary to immediately lower the equipment and point the vehicle down the slope.

Never leave the driver's seat when the vehicle is still moving or the diesel pile hammer is still in operation. Never leave the vehicle unattended with the motor running.

Check the steel cables daily for wear and possible damage. Worn and damaged cables have to be replaced immediately.

Follow all excavator/crane safety regulations as mandated by OSHA.



Safety information for the Operator

Wear a hard hat, safety boots, safety gloves, ear plugs, safety glasses and suitable, possibly reflecting, work clothes when working with the diesel pile hammer!

This reduces the risk of injuries and prevents permanent hearing and eye damage.

Familiarize yourself with the operating instructions for the diesel pile hammer and all of its accessories prior to putting the unit into operation. Make sure you have a complete set of operating instructions.

The diesel pile hammer shall be operated **only by trained personnel** that have been authorized by the foreman in charge of the driving work.

Operate the diesel pile hammer only when it is in safe working condition! Carry out a thorough inspection prior to putting the equipment into operation. Make sure all warning signs are placed at the hammer and easy to read. Do not operate a Diesel hammer that is damaged or exhibits operating problems. Inform the foreman in charge of the pile-driving work about damages. All problems must be remedied prior starting the hammer.

You must take into account that the operation of the diesel pile hammer causes blows, impact forces and vibrations in the whole pile hammer structure and in the immediate vicinity!

! DANGER !

Never work under the diesel pile hammer, lead or material to be driven! Avoid standing in the area, in which the material to be driven touches the ground! Make sure repairs are carried out only by trained experts!

Safety information for the foreman in charge of the pile driving work

The **foreman in charge** of the pile-driving work must have been trained with this unit and **must be at least 18 years old**. Provide the operator and excavator operator with information ensuring a safe execution of the work. **You are responsible for safety and all events in the work area of the diesel pile hammer.**

Please familiarize yourself with the operating instructions for the diesel pile hammer and all of its accessories prior to putting the equipment into operation. Make sure your operating instructions are complete.

Make sure the equipment and associated attached units are **inspected daily for obvious defects** prior to putting them into operation. Make sure all warning signs are placed and readable **Defects are found most often in the following components of a Diesel Hammer:**

- Tripping device
- Guiding components
- Support devices
- Pile helmet and pile guiding system
- Bridle and cable

The pile-driving work cannot be resumed with a defective unit. Inform the pile-driving personnel and the superintendent about the defects. Have the defects remedied prior to.

continued

putting the equipment into operation. Make sure only properly trained personnel carry out repair work. Do not operate the equipment until all defects have been fully remedied. Carry out a thorough inspection prior to putting the unit into operation.

Prior to putting the equipment into operation, you must make sure that nobody is on or below the equipment. Sound the horn to warn persons of the impending starting of the diesel hammer.

You must take into account that the operation of the diesel pile hammer causes blows, impact forces and vibrations in the whole pile hammer structure and in the immediate vicinity.

Never work under the diesel pile hammer, lead or material to be driven! Avoid standing in the area, in which the material to be driven touches the ground.

! WARNING !

Safety for Diesel Hammer Mechanic

- **Assembly**
- **Conversion**
- **Disassembly**
- **Maintenance**
- **Repair**

The diesel pile hammer shall be inspected prior to the first time that it is put into operation and then annually by an expert! Said expert inspection must be carried out by persons that have participated in an extensive training program in our facilities.

Assembly, conversion, disassembly, maintenance and repair work shall be carried out only by qualified and authorized personnel.

The diesel pile hammer must be shut off prior to carrying out any work on it. Danger to life!

Make sure another person cannot put the equipment into operation where work is carried out. **Danger to life!**

The following must be observed for repair and maintenance work.

- At least two persons must be present. Both must be familiar with the operating instructions and must know how to address safety questions.
- One person must be located at the main operating station to monitor the safety of the other persons. Said person must have access to an **EMERGENCY** switch (or shutoff cable for the fuel supply) in all situations.
- An uninterrupted communication must be possible between the involved persons.
- The work area must be fully lighted.

Maintenance and repair work can be carried out by one person only, when the pile hammer is completely shut off and all means to put it into operation are blocked.

Chapter 2

Conversion Charts



Conversion Factors

mass	1 t (metric)	=	1000	kg	1 kg	=	0.001	t (metric)
	1 t (metric)	=	1.102	t (US)	1 t (US)	=	0.9072	t (metric)
	1 kg	=	2.204	lbs	1 lbs	=	0.4536	kg
force	1 kN	=	102	kp	1 kp	=	0.0098	kN
	1 kN	~	220	Lbf (lb)	1 lbf	=	0.0045	kN
energy	1 Nm	=	0.102	kpm	1 kpm	=	9.81	Nm
	1 Nm	=	0.7375	ft.lbs	1 ft. lbs	=	1.356	Nm
distance	1 mm	=	0.0393	inch	1 inch	=	25.4	mm
	1 cm	=	0.3937	inch	1 inch	=	2.54	cm
	1 m	=	39.37	inch	1 inch	=	0.0254	m
	1 m	=	3.2808	ft	1 ft	=	0.3048	m
	1 m	=	1.0936	yd	1 yd	=	0.9144	m
area	1 cm ²	=	0.155	in ²	1 in ²	=	6.4516	cm ²
	1 ft ²	=	0.093	m ²	1 m ²	=	10.764	ft ²
volume	1 cm ³	=	0.061	in ³	1 in ³	=	16.38	cm ³
	1 L	=	1000	cm ³	1 cm ³	=	1.000	mL
	1 L	=	0.2642	gal	1 gal	=	3.785	L
	1 m ³	=	1000	L	1 m ³	=	264.17	gal

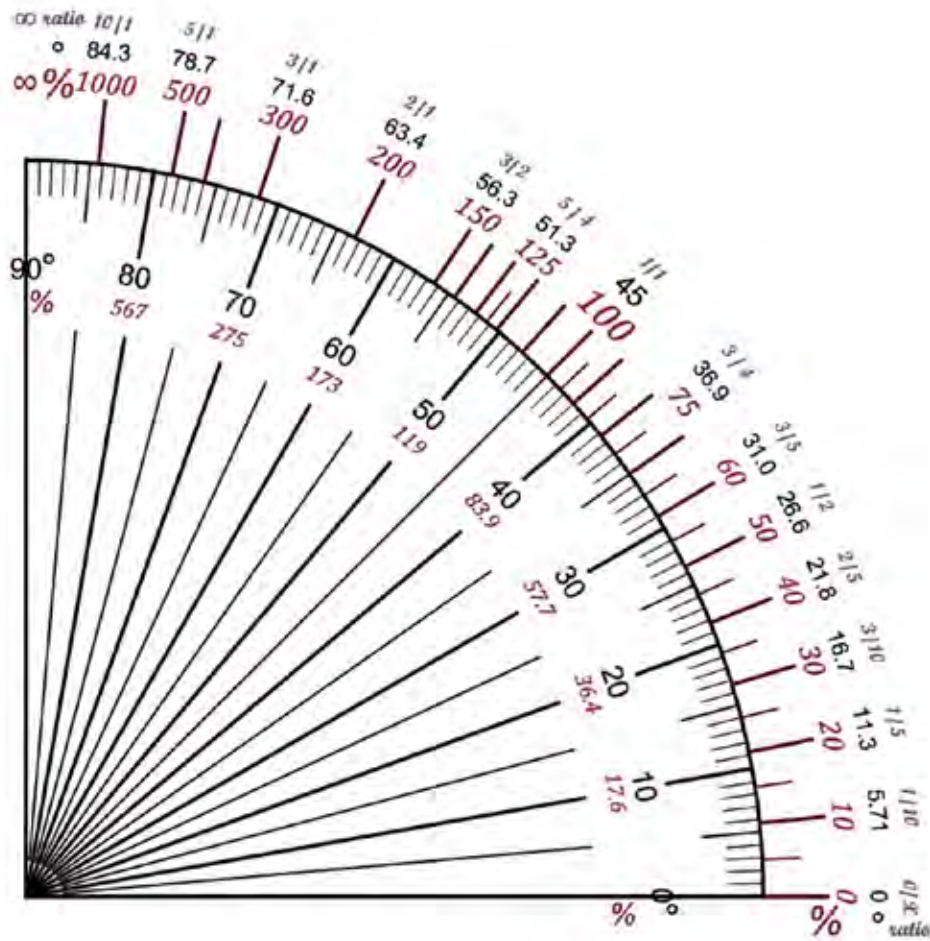
Angle Conversion to Ratio

Chapter 3

Technical Data

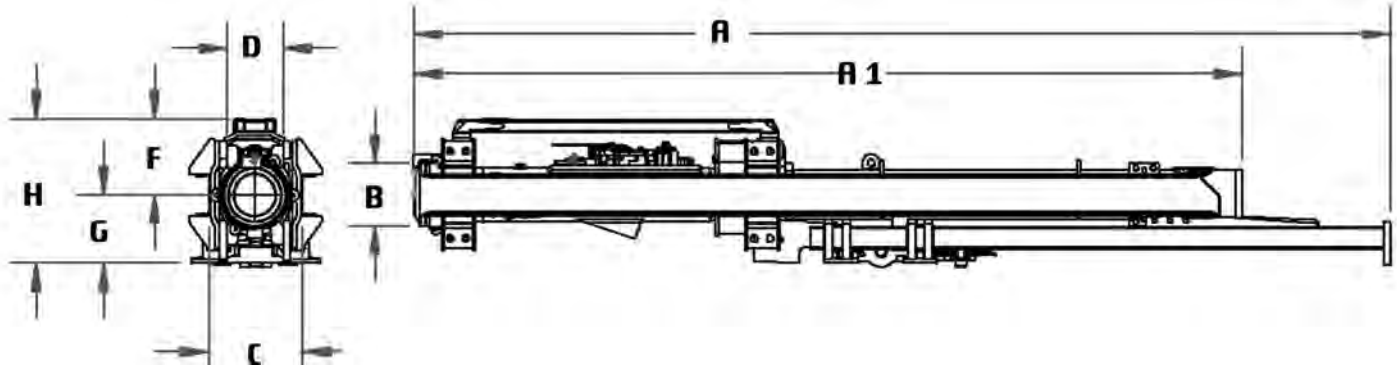
Diesel Hammer D6-D50 Data Approximate

*Approximately

Model #		D6-42/D8-242	D12-42	D19-42	D25-32/D30-32	D36-32/D46-32/ D50-32
Weight of hammer (without guiding):	lbs	5,401/6,076	8,296	10,503	15,113/16,251	21,705/24,859/ 25,053
Weight of piston:	lbs	1,323/1,764	2,822	4,012	5,512/6,614	7,937/10,141/ 11,023
Energy per blow Max/Min:	ft lbf min.	12,539– 7,081/18,760– 9,480	29,798– 14,973	42,410–21,463	58,245– 29,484/69,895– 35,381	83,860–40,935/ 107,315–54,358 116,643–59,727
Number of blows: Min/Max		39–52/37–52	37–52	37–52	37–52/36–52	36–52/35–52/ 35–52
Consumption Diesel fuel: Lubrication oil:	gph	1/1 .07/.13	1.2 .13	2 .16	2.1/2.6 .26	3/4.3/4.4 .5/.53/.53
Volume Diesel oil tank: Lube tank:	gal	5/5.08 1.32/1.59	6.3 1.7	18.8 5.3	17.7 5	23.5 4.5
Dimensions						
A1 length of hammer	ft	14' 1"/15' 5"	16' 7"	16' 7"	17' 9.4"	18' 4"
A Hammer length w/ starter guides	ft	15' 9"/17' 1"	18' 2"	18' 3"	21' 3"	21'
B Ø of impact Block	ft	1' 2"	1' 4"	1' 4"	1' 10"	2' 2"
C Guiding Width	ft	1' 9"	1' 9"	2' 2"	2' 2"	32"
D Width of Hammer	ft	1' 4"	1' 5"	1' 6"	2'	31"
F Hammer center to Pump Guard	ft	1'	1'	1' 1"	1' 3"	1' 6"
G Hammer Center to Trip	ft	9.6"	8"	9"	1' 5.3"	11"/10"/10"
H Hammer Depth	ft	1' 11"	1' 9"	2' 2"	3'	3' 4"

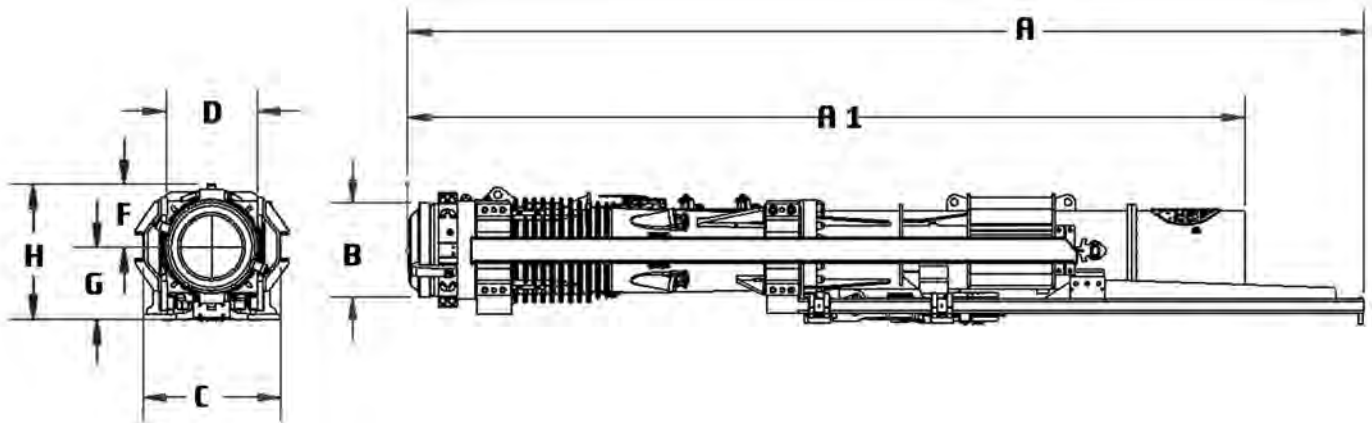
Diesel Hammer D62–D280 Data Approximate

Model #		D62-22/D70-32	D80-23/D100-13	D125-32/ D138-32	D160-32/D180-32	D225-22/D250/D280
Weight of hammer (without guiding):	lbs	31,650/ 34,357	38,559/ 42,968	61,613/64,479	81,948/86,358	113,693/ 120,439/ 127,929
Weight of piston:	lbs	13,670/ 15,432	17,637/22,046	27,558/30,424	35,274/39,683	49,612/55,116/ 61,729
Energy per blow Max/Min:	ft lbf	161,526– 78,919/ 172,590–	196,929–126,123/ 246,006–157,735	307,563–184,538/ 340,016–217,581	449,913–283,224/ 449,913–283,224	564,973–292,812/ 631,352–331,902/ 688,145–357,718
Number of blows: Min/Max	min.	110,634 36–50/ 36–45	36–45	36–45	36–46	36–50
Consumption Diesel fuel:	gph	5.28/6	6.6/7.93	9.5/10.3	13.2	16.9/19/21
Lubrication oil:		.53/.85	.76	1/1.1	1.3	1.53
Volume Diesel oil tank:	gal	25.8	41	50.2	63.4	121
Lube tank:		8.3	8.5	16	21	26.4
Dimensions						
A1 length of hammer	ft	20' 3"/22' 2"	23.65'/24.18'	25' 7"/26' 2"	25' 9"/27' 4"	28'/28.6'/29'
A Hammer length w/starter guides	ft	22' 7"/24'	27'/27.6'	29' 1"/29' 6"	29' 2"/ 30' 8"	30'/30.4'/31'
B Ø of impact Block	ft	2' 4"	2.69'	3'	3' 4"	3.9'
C Guiding Width	ft	3' 6"/2' 8.6"	4	4'	4'	5.7'
D Width of Hammer	ft	30"	2.63'/2.92'	3' 4.6"	3' 8"	4.4'
F Hammer center to Pump Guard	ft	2' 2"/1' 7"	1.80'	1' 10"	2'	2.8'
G Hammer Center to Trip	ft	1' 9"/1' 3"	2.1'	1' 2.6"	1' 4"	3.3'
H Hammer Depth	ft	4' 4.5"	4' 2"	4' 9"	5' 6"	6.1'

Diesel Hammer Pump Settings for D6-D125 Approximate

D6-42			
Pump Setting 1	49-64%	9.6 kNm	7,090 ft.lbs.
Pump Setting 2	66-77%	11.2 kNm	8,300 ft.lbs.
Pump Setting 3	83-90%	14.1 kNm	10,430 ft.lbs.
Pump Setting 4	100%	17.0 kNm	12,570 ft.lbs.

D8-52			
Pump Setting 1	49-64%	12.9 kNm	9,480 ft.lbs.
Pump Setting 2	66-77%	16.9 kNm	12,464.8 ft.lbs.
Pump Setting 3	83-90%	21.1 kNm	15,570 ft.lbs.
Pump Setting 4	100%	25.4 kNm	18,760 ft.lbs.

D12-42			
Pump Setting 1	49-64%	20.5 kNm	15,000 ft.lbs.
Pump Setting 2	66-77%	27.7 kNm	19,690 ft.lbs.
Pump Setting 3	83-90%	33.6 kNm	24,760 ft.lbs.
Pump Setting 4	100%	40.5 kNm	29,840 ft.lbs.

D19-42			
Pump Setting 1	49-64%	29.2 kNm	21,510 ft.lbs.
Pump Setting 2	66-77%	38.0 kNm	28,035 ft.lbs.
Pump Setting 3	83-90%	47.8 kNm	35,260 ft.lbs.
Pump Setting 4	100%	57.6 kNm	42,480 ft.lbs.

D25-32			
Pump Setting 1	49-64%	40.0 kNm	29,510 ft.lbs.
Pump Setting 2	66-77%	58.5 kNm	38,830 ft.lbs.
Pump Setting 3	83-90%	71.1 kNm	52,470 ft.lbs.
Pump Setting 4	100%	79.0 kNm	58,300 ft.lbs.

D30-32			
Pump Setting 1	49-64%	47.9 kNm	35,400 ft.lbs.
Pump Setting 2	66-77%	70.0 kNm	51,630 ft.lbs.
Pump Setting 3	83-90%	85.4 kNm	62,920 ft.lbs.
Pump Setting 4	100%	94.8 kNm	69,923 ft.lbs.

D36-32			
Pump Setting 1	49-64%	57.6 kNm	42,500 ft.lbs.
Pump Setting 2	66-77%	75.1 kNm	55,410 ft.lbs.
Pump Setting 3	83-90%	94.5 kNm	69,680 ft.lbs.
Pump Setting 4	100%	113.8 kNm	83,950 ft.lbs.

D46-32			
Pump Setting 1	49-64%	73.7 kNm	54,320 ft.lbs.
Pump Setting 2	66-77%	96.0 kNm	70,805 ft.lbs.
Pump Setting 3	83-90%	120.7 kNm	89,040 ft.lbs.
Pump Setting 4	100%	145.5 kNm	107,280 ft.lbs.

D50-32			
Pump Setting 1	49-64%	81.2 kNm	59,727 ft.lbs.
Pump Setting 2	66-77%	104.7 kNm	76,985 ft.lbs.
Pump Setting 3	83-90%	131.7 kNm	96,814 ft.lbs.
Pump Setting 4	100%	158.6 kNm	116,643.4 ft.lbs.

D62-22			
Pump Setting 1	49-64%	107.4 kNm	79,148 ft.lbs.
Pump Setting 2	66-77%	145.7 kNm	107,490 ft.lbs.
Pump Setting 3	83-90%	181.9 kNm	134,160 ft.lbs.
Pump Setting 4	100%	219.2 kNm	161,526 ft.lbs.

D70-32			
Pump Setting 1	49-64%	120.7 kNm	89,043 ft.lbs.
Pump Setting 2	66-77%	160.9 kNm	118,739 ft.lbs.
Pump Setting 3	83-90%	205.3 kNm	151,452 ft.lbs.
Pump Setting 4	100%	246.8 kNm	182,074 ft.lbs.

D80-23			
Pump Setting 1	49-64%	171.1 kNm	126,180 ft.lbs.
Pump Setting 2	66-77%	196.7 kNm	145,100 ft.lbs.
Pump Setting 3	83-90%	239.8 kNm	176,840 ft.lbs.
Pump Setting 4	100%	267.3 kNm	197,150 ft.lbs.

D100-13			
Pump Setting 1	49-64%	213.8 kNm	157,685 ft.lbs.
Pump Setting 2	66-77%	257.9 kNm	190,210 ft.lbs.
Pump Setting 3	83-90%	299.7 kNm	221,010 ft.lbs.
Pump Setting 4	100%	334.1 kNm	246,390 ft.lbs.

D125-32			
Pump Setting 1	49-64%	267.3 kNm	197,150 ft.lbs.
Pump Setting 2	66-77%	313.2 kNm	231,020 ft.lbs.
Pump Setting 3	83-90%	346.6 kNm	255,660 ft.lbs.
Pump Setting 4	100%	417.6 kNm	308,025 ft.lbs.

Diesel Hammer Pump Settings for D138-D280 Approximate
D138-32

Pump Setting 1	49-64%	274.8 kNm	217,600 ft.lbs.
Pump Setting 2	66-77%	354.9 kNm	261,800 ft.lbs.
Pump Setting 3	83-90%	410.3 kNm	302,600 ft.lbs.
Pump Setting 4	100%	460.9 kNm	340,000 ft.lbs.

D180-32

Pump Setting 1	49-64%	368.3 kNm	271,640 ft.lbs.
Pump Setting 2	66-77%	463.0 kNm	341,500 ft.lbs.
Pump Setting 3	83-90%	535.2 kNm	394,700 ft.lbs.
Pump Setting 4	100%	601.3 kNm	443,500 ft.lbs.

D160-32

Pump Setting 1	49-64%	327.4 kNm	241,470 ft.lbs..
Pump Setting 2	66-77%	406.3 kNm	299,630 ft.lbs.
Pump Setting 3	83-90%	443.6 kNm	327,230 ft.lbs.
Pump Setting 4	100%	534.5 kNm	394,250 ft.lbs.

D225-22

Pump Setting 1	49-64%	399.5 kNm	276,837 ft.lbs.
Pump Setting 2	66-77%	545.5 kNm	401,131 ft.lbs.
Pump Setting 3	83-90%	637.7 kNm	468,928 ft.lbs.
Pump Setting 4	100%	768.4 kNm	564,973 ft.lbs.

D250-22

Pump Setting 1	49-64%	455.1 kNm	334,617 ft.lbs.
Pump Setting 2	66-77%	609.6 kNm	448,260 ft.lbs.
Pump Setting 3	83-90%	712.7 kNm	524,022 ft.lbs.
Pump Setting 4	100%	858.6 kNm	631,352 ft.lbs.

D280-22

Pump Setting 1	49-64%	486.7 kNm	357,835 ft.lbs.
Pump Setting 2	66-77%	692.5 kNm	509,227 ft.lbs.
Pump Setting 3	83-90%	832.9 kNm	612,449 ft.lbs.
Pump Setting 4	100%	935.9 kNm	688,145 ft.lbs.

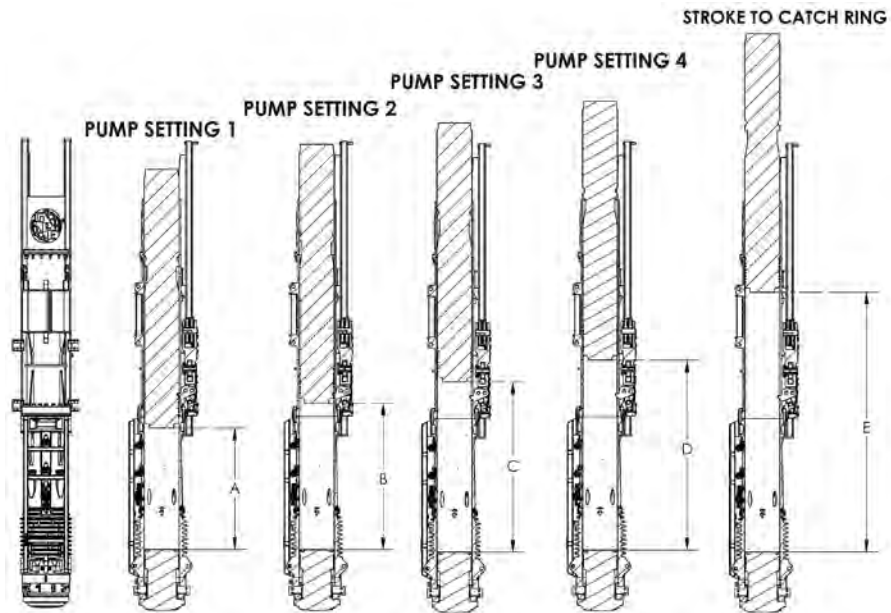
Pump Setting to Stroke Range

	PUMP S1	PUMP S2	PUMP S3	PUMP S4	STROKE TO CATCH RING
	A	B	C	D	E
D6	5' 3.5"	6' 2.7"	7' 8.8"	9' 4.8"	11' 7"
D8	5' 3.6"	5' 8.5"	8' 8.1"	10' 6.1"	11' 7"
D12	5' 3.1"	6' 9.8"	8' 7.7"	10' 5.6"	13' 2"
D19	5' 3.5"	6' 9.9"	8' 7.9"	10' 5.7"	14' 2"
D25	5' 3.5"	7' 0.5"	9' 5.2"	10' 5.7"	14' 9"
D30	5' 3.5"	7' 8.1"	9' 5.1"	10' 5.7"	14' 9"
D36	5' 1.6"	6' 9.8"	8' 7.8"	10' 5.7"	13' 3"
D46/D50	5' 3.6"/5' 4.1"	6' 9.8"	8' 7.8"	10' 5.8"	13' 3"
D62/D70	5' 7.7"	7' 8.6"	9' 8.1"	11' 8.2"	14' 9"
D80	7' 1.5"	8' 2.8"	10' 0.2"	11' 1.7"	16' 9"
D100	7' 1.5"	8' 6.3"	10' 0.2"	11' 1.6"	16' 9"
D125	6' 6.9"	8' 3.8"	9' 2.8"	11' 1.6"	17' 5"
D138	7' 1.5"	8' 6.0"	9' 9.5"	11' 1.8"	17' 5"
D160	6' 8.5"	8' 4.9"	9' 2.8"	11' 1.8"	18' 5"
D180	6' 8.5"	8' 6.1"	9' 9.5"	11' 1.8"	18' 5"
D225	5' 9"	8' 1"	9' 5"	11' 2"	19' 9"
D250	6' 2"	8' 1"	9' 2"	11' 2"	19' 9"
D280	5' 8"	8' 1.8"	9' 9"	11' 2"	19' 9"

Sound Emission

The amount of noise produced when driving piles with a diesel pile hammer depends on several factors:

1. Explosion and Exhaust Noise

The explosion and exhaust noise is not, as often supposed, the main source of noise. A noise reduction mantle would reduce the overall sound level only a very small degree. The installation of a noise reduction mantle also inhibits proper escape of the exhaust gases and, therefore, reduces the fresh air supply for scavenging. This would impede the proper function of the pile hammer.

2. Noise generated by the piston hitting the impact block.

This noise is inside the lower cylinder of the hammer, so it is not the main source of noise.

3. Noise generated by impact block hitting the pile helmet.

This is where the main noise develops. It can be reduced to a large extent by using a very "soft" pile helmet cushion.

4. Noise generated by the pile helmet hitting the piles.

This is another main source of noise. In order to soften the impact it is necessary to use a soft cushion here, so that a reduction of noise can be achieved.

5. Noise generated from the piles themselves.

By taking the above-mentioned measures the structure-borne noise generation of the piles can be diminished considerably. Of course, the noise development also depends on the kind of piles used. If steel piles are used, the noise development will be higher than for concrete piles. Moreover the soil conditions

have an effect on the generation of noise. If the soil is rocky, arid, or hard, there will be more vibration of the piles than if the soil consists of coarse clay. For the above reasons it is impossible to predict the exact noise level for a particular construction site.

The noise levels measured when pile driving with a diesel pile hammer is actually somewhat higher than the noise levels generated by alternate methods of pile installation: rotary drilling, percussion drilling or construction of diaphragm walls, but when examining the noise on a construction site, it is important to compare the noise level in relation to the duration of the noise. If this is done, the noise irritation caused by a diesel pile hammer will be the relatively insignificant.

The data sheet below was made at the factory test stand on a refusal pile.

Diesel Hammer Type	Sound pressure level dB(A) at distance from hammer	
	7m (13 ft)	300m (984 ft)
D8-22	100	73
D12-32	102	76
D19-42	106	79
D25-32	110	84
D30-32	110	84
D36-32	111	85
D46-32	111	85
D50-32	111	85
D62-22	114	86
D70-32	114	86
D80-32	116	88
D100-13	119	92
D125 / D138	n.a.	n.a.
D160 / D180	n.a.	n.a.
D225 / D250	n.a.	n.a.

Exhaust Emission Data

For diesel hammers a reliable quantitative exhaust research does not exist. Following reasons don't allow any warranted statement:



- Fuel consumption depends on the driving conditions
- The fuel burning depends on the climate conditions exactly
- Measurements under jobsite conditions require a huge effort
- Measurement results will be falsified by imperfect conditions

Calculated emission values based on fuel consumption are theoretical and don't consider any driving conditions neither climate nor fuel combustion conditions.

More environmental fuel types are suitable as replacement for diesel fuel with minor reduction of diesel hammer performance (see Chapter 11 on fuel types). Attention is required in some cases for the specification of the lubrication oil and additional maintenance.

For information only: The table below the values of the Tier 2 exhaust emission standard based on the theoretical horsepower (kW) of the diesel hammer.

Diesel hammer type	Energy Output range (kW)	NMHC + Nox (g/kWh)	CO (g/kWh)	PM (g/kWh)
D8-22	24	7.5 (5.6)	5.5 (4.1)	0.6 (0.45)
D12-42	27	7.5 (5.6)	5.5 (4.1)	0.6 (0.45)
D16-32	30	7.5 (5.6)	5.5 (4.1)	0.6 (0.45)
D19-42	45	7.5 (5.6)	5.5 (4.1)	0.6 (0.45)
D25-32	48	7.5 (5.6)	5.0 (3.7)	0.4 (0.30)
D30-32	60	7.5 (5.6)	5.0 (3.7)	0.4 (0.30)
D36-32	69	7.5 (5.6)	5.0 (3.7)	0.4 (0.30)
D46-32	96	6.6 (4.9)	5.0 (3.7)	0.4 (0.30)
D62-22	120	6.6 (4.9)	5.0 (3.7)	0.4 (0.30)
D80-12	151	6.6 (4.9)	3.5 (2.6)	0.2 (0.15)
D100-13	181	6.6 (4.9)	3.5 (2.6)	0.2 (0.15)
D125-32	220	6.6 (4.9)	3.5 (2.6)	0.2 (0.15)
D138-32	250	6.4 (4.8)	3.5 (2.6)	0.2 (0.15)
D160-32	288	6.4 (4.8)	3.5 (2.6)	0.2 (0.15)
D180-32	325	6.4 (4.8)	3.5 (2.6)	0.2 (0.15)

Chapter 4

Transport

Transport of Diesel Hammer

! WARNING !

General preparation

The diesel pile hammer shall only be transported with an installed locking screw (1) and impact block clamp (3). If this is omitted, a shift in the center of gravity could cause sudden movements of the diesel pile hammer! The piston and impact block may accidentally shift to the other end position! **Crushing and impact danger!**

The diesel pile hammer and its accessories must be packaged, loaded and transported carefully to prevent damage! Check the diesel pile hammer and all accessories regarding completeness and damages after delivery. Immediately notify the shipping agency or the appropriate dealer about problems.

The following transport

Safety Devices must be installed prior to transporting the diesel pile hammer.

1. Locking screws. These piston locking screws prevent moving of the piston during transport. This prevents sudden shifts in the center of gravity of the diesel pile hammer. Omitting the installation of these bolts may cause sudden movements as well as damages, e.g. to the catch ring. The piston safety screws must be screwed in fully and tightened. The piston must be in lowered position. Two piston safety bolts must be used for types D80-23 through D100-13.

2. Exhaust cover. The exhaust covers (2) pieces; 4 pieces for type D80 and above) prevent the entering of water,

dust and foreign bodies. Screw the exhaust covers into the respective thread fitted at the exhaust

3. Impact block clamp. The impact block clamp prevents a moving of the impact block during transport. Without the impact block clamp, the impact block may accidentally fall to the other end position. Install the impact block clamp as shown in the illustration.

4. Protective cap. The protective cap prevents the entering of water, dust and foreign bodies. Attach the protective cap with the help of the two chains. Attach the hook located at the end of each chain to the respective eyelet.

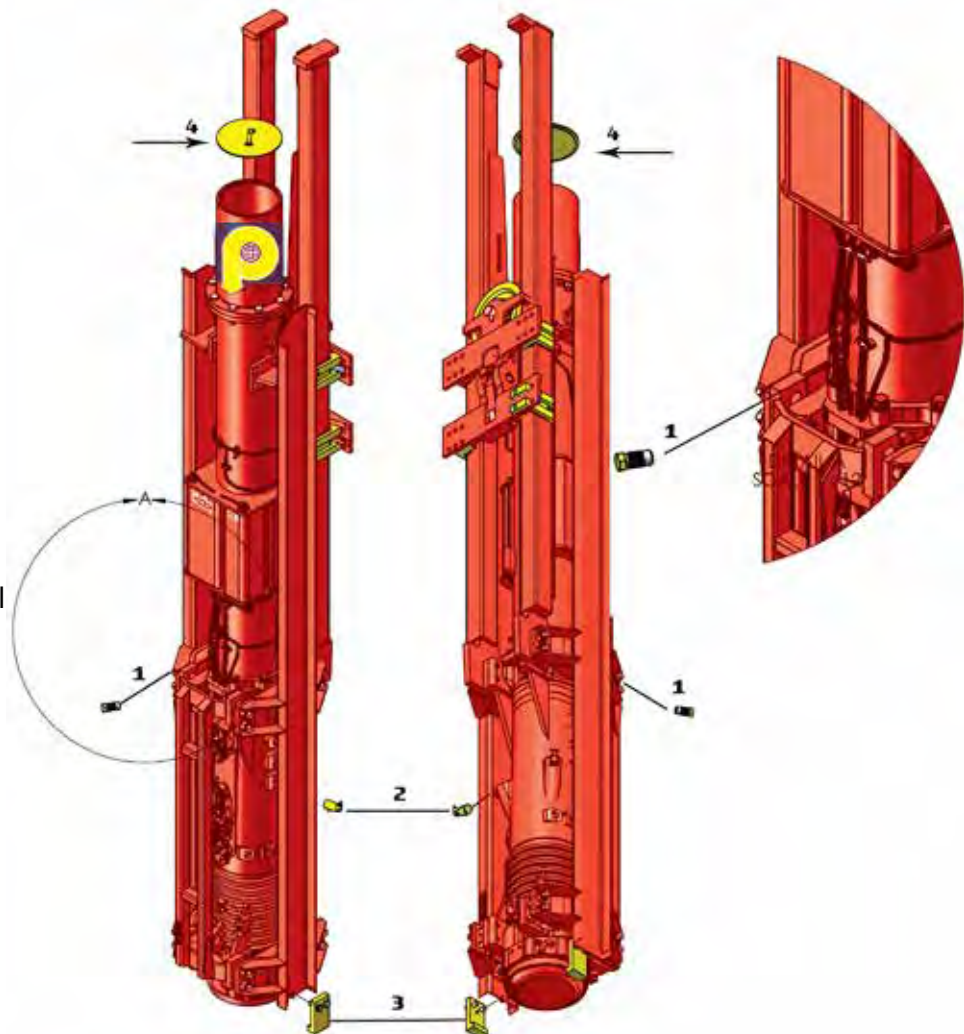

Lifting Cables and Ground Support

Prior to each use, the transport cables must be inspected visually. **Use only approved cables to transport piles!** Immediately remove and dispose of damaged cables! Use only steel cables that exhibit the proper load capacity and length. (see table below)!

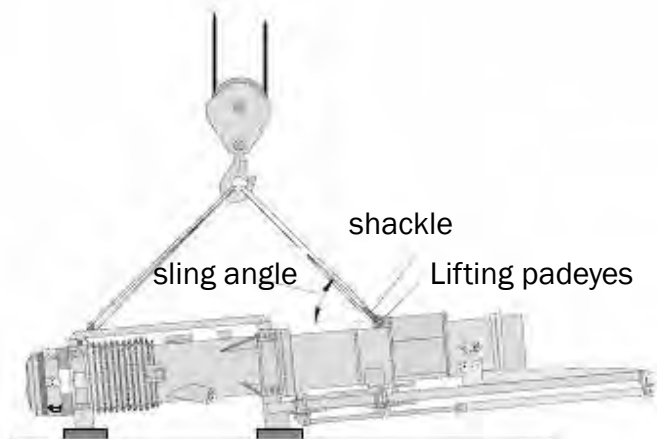

Never Walk Under Suspended Loads!

Minimum required cable diameters for lifting the diesel hammer

Type of diesel pile hammer	Max. total weight (lbs.)	2 steel cable at sling angle sling diameter (inch)	approx. min. sling length (ft)	Shackle size	Eyelet Diam.
D 8-52	6,076	1/2" at 45°	5.75'	17 ton	1.97"
D 12-42	8,296	9/16" at 45°			
D 19-42	10,503	5/8" at 45°			
D 25-32	15,113	7/8" at 45°	6.25'	17 ton	1.97"
D 30-32	16,215				
D 36-32	21,705	1" at 45°	6.75'	17 ton	1.97"
D 46-32	24,859				
D50-32	25,053				
D 62-22	31,650	1-1/8" at 45°	7.75'	17 ton	1.97"
D70-32	34,357				
D 80-13	38,559	1-3/8" at 45°	9.00'	25 ton	2.44"
D 100-13	42,968				
D 125-32	61,613	1-1/2" at 45°	10.00'	25 ton	2.90"
D 138-32	64,479				
D 160-32	81,948	1-3/4" at 60°	15.00'	25 ton	3.22"
D 180-32	86,358				
D 225-22	113,693	2-1/4" at 60°	18.00'	55 ton	3.94"
D 250-22	120,439				
D 280-22	127,929				

Make sure that the ground for laying down the diesel hammer is even and level . If you don't set down the diesel hammer to a concrete slab area, use 3" thick wood planks to prevent the hammer sinking into the ground or tipping over!



Securing the Diesel Hammer for Trailer Transport

! DANGER !

The responsibility for the secure transport of the diesel hammer or pile driving equipment shall be assumed by the contractor or trucking company.

Unsecured or incorrectly secured equipment on transport trailers can cause deadly accidents, by falling off or shifting the load during sudden braking or steering. Improperly secured heavy equipment may shift during transport causing damage.



Securing the diesel hammer on a trailer



Chapter 5

Assembly & Mode of Operation

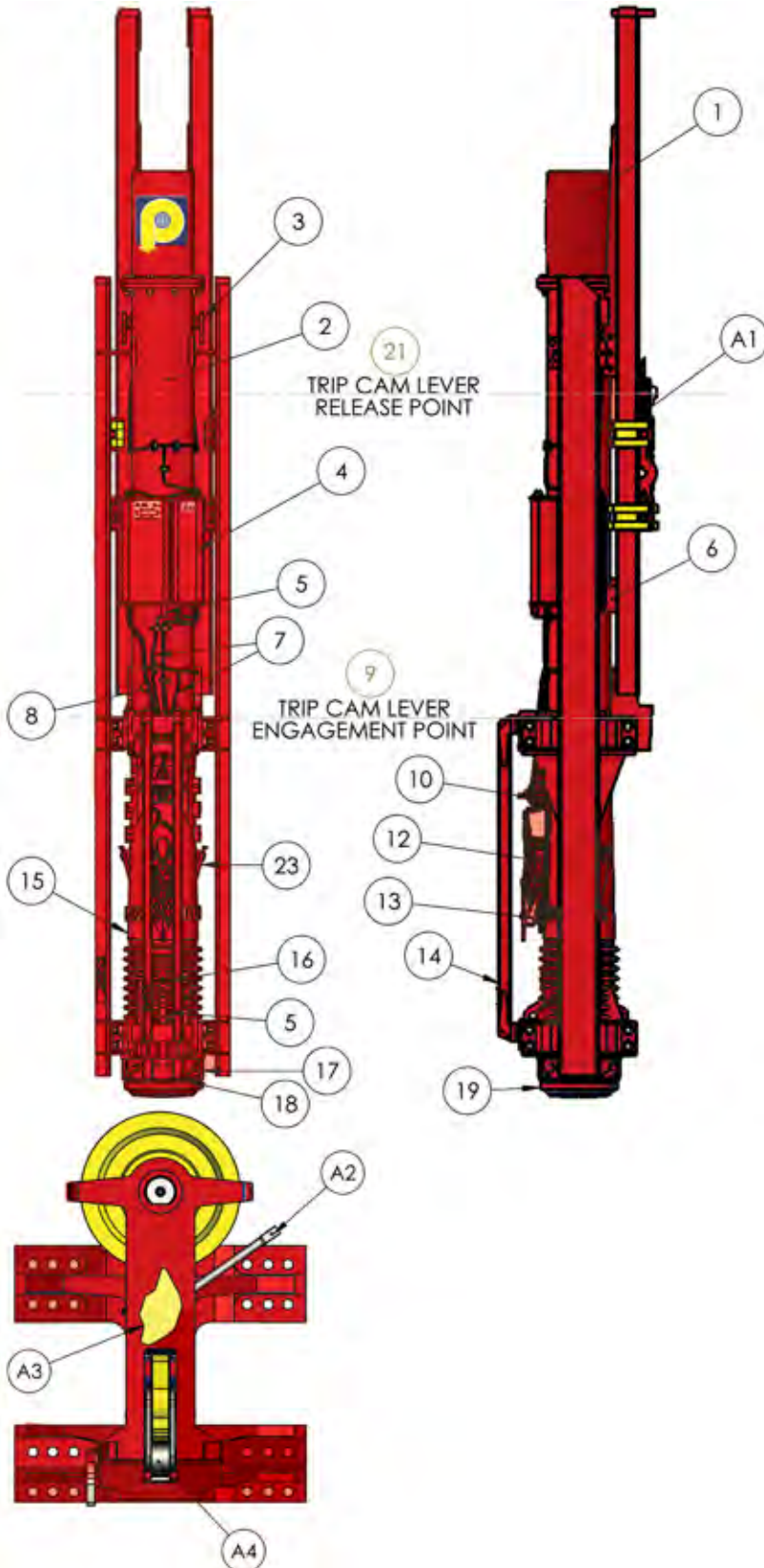
Components of Diesel Pile Hammer

- 1 > upper cylinder extension**
with catch ring groove
- 2 > upper cylinder**
- 3 > lifting ears**
- 4 > fuel tank with integrated**
lube oil tank
- 5 > Lifting padeyes**
- 6 > lifting dogs**
- 7 > lubrication lines**
- 8 > locking screw (piston)**
- 9 > trip cam lever engaging point**
- 10 > lubrication pump**
- 11 > fuel / breather line**
- 12 > fuel control pump**
- 13 > injection valve**
- 14 > pump guard**
- 15 > lower cylinder**
- 16 > blow out plug**
- 17 > outer cylinder end ring**
- 18 > rubber ring**
- 19 > impact block**
- 20 > key plate bolts**
- 21 > trip cam lever release point**
- 22 > hammer guides (offset version)**
- 23 > exhaust ports**
- 24 > short upper ending with**
catch ring groove
- A1 > guide gibs**

- A = tripping device**
- A2 > lever for activating driving pin**
- A3 > driving pin**
- A4 > trip cam lever**



Section View of Diesel Pile Hammer

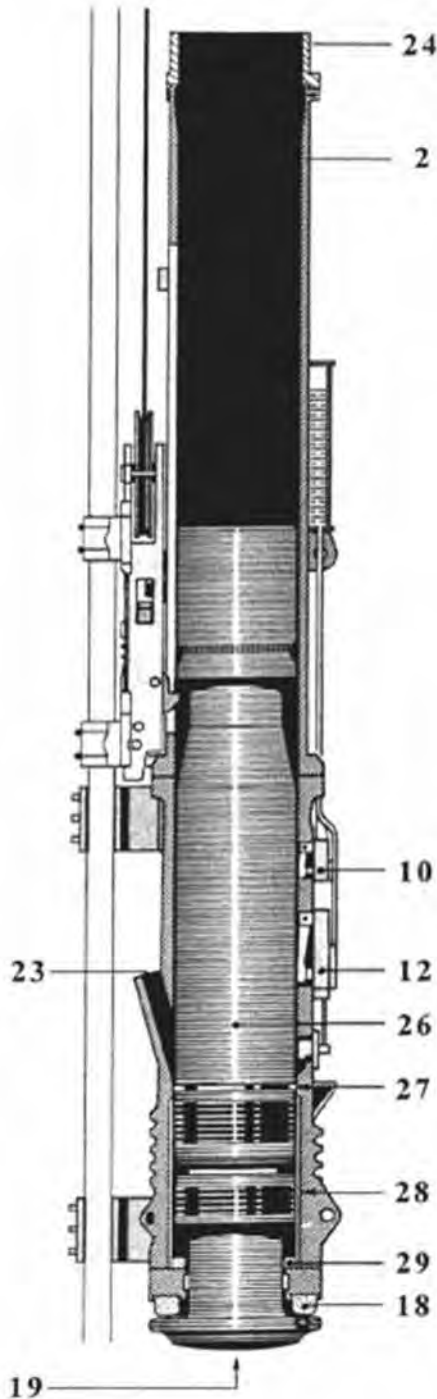

2 > upper cylinder

10 > lubrication pump

11 > fuel ventilation line

12 > fuel control pump

18 > rubber ring

19 > impact block

23 > exhaust ports

24 > upper endring with catch ring groove

26 > piston

27 > piston catch ring

28 > cylinder sleeves

29 > inner damping ring

Operating Principle

Diesel pile hammers are used to drive piles into a supporting soil layer. The mode of operation is similar to that of a hammer used to drive a nail.

The piston activates the pump lever during its fall.

The Diesel fuel is in that manner sprayed onto the surface of the impact block (1). The air in the cylinder is compressed as soon as the piston runs past the exhaust openings. The strongly increasing compression pressure drives the piston and the impact head below it on the material to be driven.

The following occurs when the hammer impacts (2):

- The pile is driven into the soil
- The Diesel fuel is atomized

The atomized Diesel fuel ignites, because the enormous compression causes a substantial increase in the air temperature of the cylinder volume (working principle of the Diesel engine). There is an explosion.

The explosion causes the following:

- It drives the pile further into the soil,
- The piston is driven upward (stroke).

The exhaust openings become exposed with the upward driving of the piston. **The pressure in the cylinder volume causes the exhaust gases to be pushed through the exhaust (3).** This reduces the pressure in the cylinder to zero.

The piston continues to move upward. This causes a suction effect (vacuum) in the cylinder volume. **Said vacuum ensures that fresh air is suctioned in to purge the cylinder volume (4).** This is called scavenging.

The pump lever is released during the further upward movement of the piston. The pump lever returns to its original position. Diesel fuel is again supplied to the fuel control pump

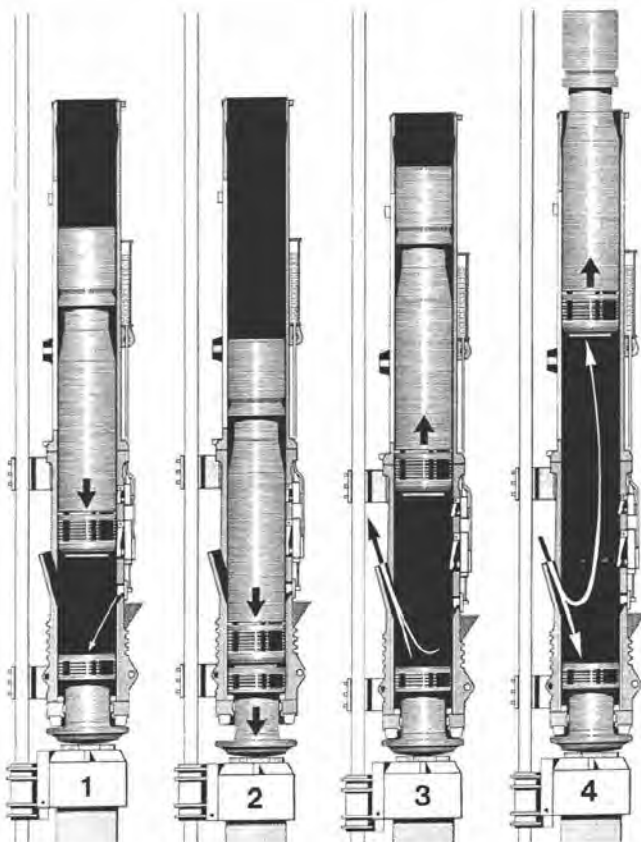

Pile Driving Equipment **General Information**

Lead Systems—Guiding Options

The following indicates and describes different possibilities to guide the Diesel pile hammer with a lead. You must consult with Pileco, Inc. should you decide on a different guiding system for the Diesel Pile Hammer.



! D A N G E R !

**Following the operating instructions for the lead—
Use only leads with a sufficiently high capacity and
stability. *Danger to life!***

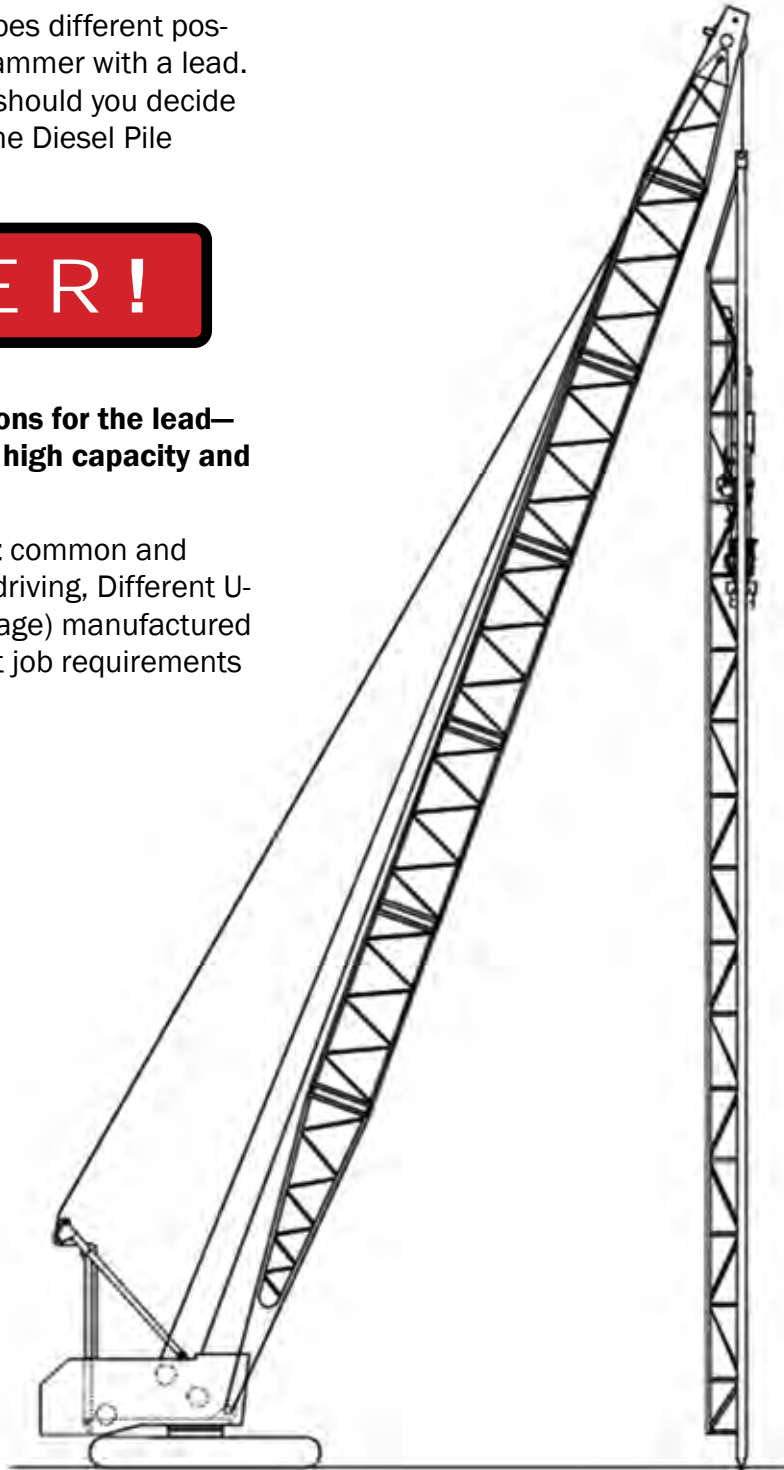
U-type lead systems are the most common and most economical solution for pile driving, Different U-type lead systems (see following page) manufactured by Pileco, Inc. accomplish different job requirements



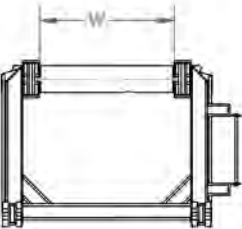

U-type Lead Systems			
			
Fixed Lead	Caisson-type/ Offshore Lead	Swinging Lead	
 <p>U Leads</p>	Type	W inch	Max. Suitable Diesel Hammer Size
	U21	21-1/2	up to D19
	U26	26-1/2	up to D30
	U32	32-1/2	up to D62
	A104-36	42-1/2	up to D138
	A104-42	48-1/2	up to D180
	A104-48	54-1/2	up to D180
	A104-66	66-1/2	up to D180
	OS-98	68-1/2	up to D280
OS-120	68-1/2	up to D280	

Diesel Pile Hammer Conversion for Driving of Batter Piles

Driving batter piles with a larger inclination than shown below requires a upper cylinder extension. This upper cylinder extension replaces the short upper end ring with catch groove bolted to the upper cylinder.

Calculate the required batter prior to putting the equipment into operation. Check following points using the diagram below:

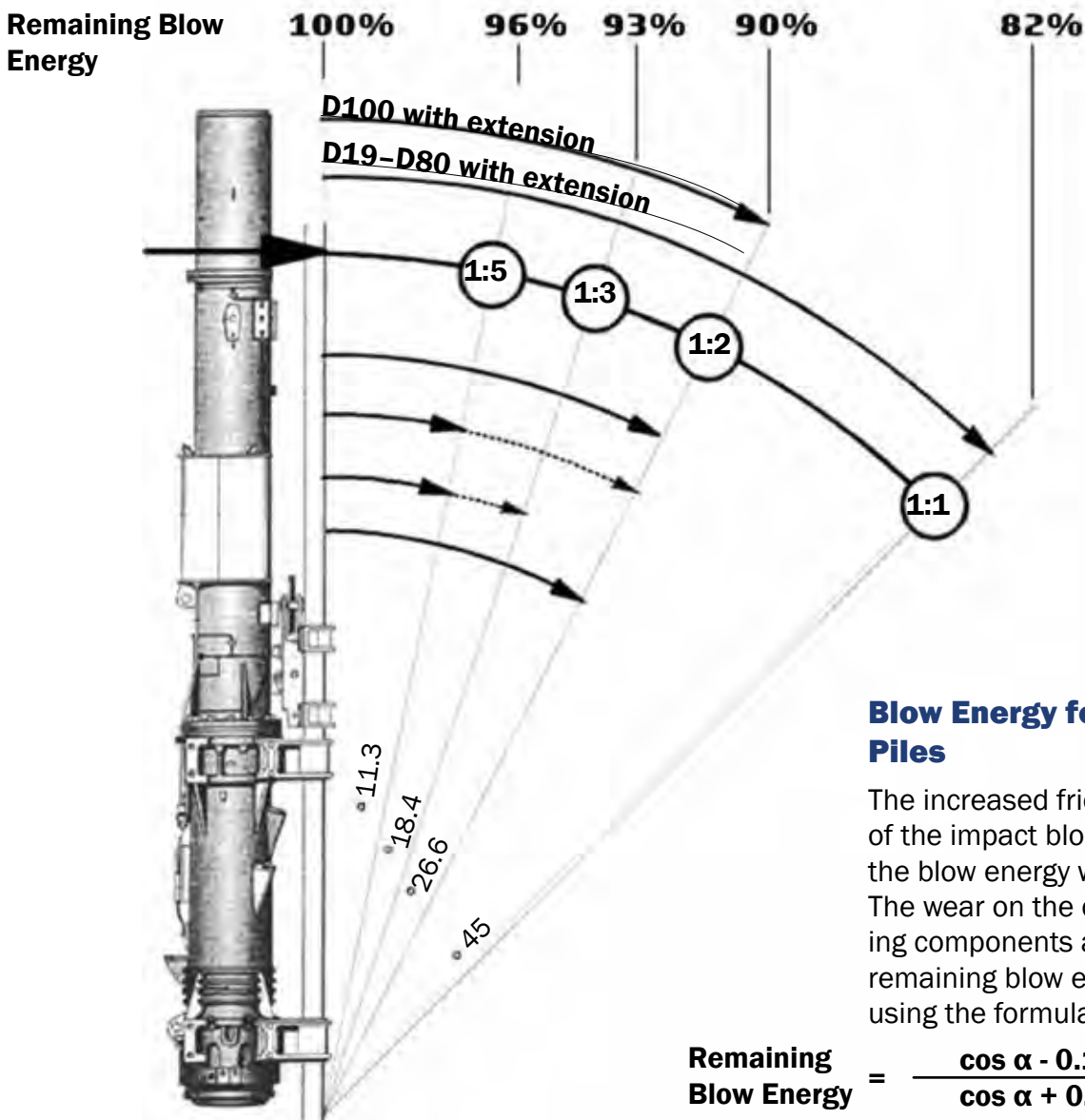

Cylinder Extension Assembly and Disassembly

When required, the upper cylinder section of diesel pile hammers D19-42 through D100-13 can be extended. For these Diesel pile hammers, such an extension is required for a batter of more than 1:5.

! D A N G E R !

Conversion work can be carried out only on a safely supported diesel pile hammer in the lower position in the lead, resting on the material to be driven. Use a height safety device to prevent a fall when climbing up the lead! Conversion work shall only be carried out by qualified and authorized personnel.

Hard hat, safety boots and suitable work clothes must be worn! A life vest must be worn when working above a water surface!



Work Stages: (See Components of Diesel Hammer)

- 1.** Disassemble the upper end ring. To do so, unscrew all hexagonal bolts of the upper end ring. Remove the upper end ring by lifting it upward.
- 2.** Install the supplied extension for the upper cylinder section.
- 3.** Bolt the extension of the upper cylinder section (1) to the upper cylinder section. Use the bolts of the upper end ring. Solidly tighten the bolts (bolt torque values see Chapter 13). Replace missing or damaged bolts or nuts with new ones.

- 4.** Install the supplied extension for the lubricant line. The disassembly of the extension is the reverse of the above.

! W A R N I N G !

Diesel pile hammers D12-42 through D180-32 shall be operated only with an installed upper end ring or extension of the upper cylinder section. If the upper end ring is not mounted the piston can jump out of the cylinder when overstroking—DANGER TO LIFE !****

The catch groove designed with the upper endring or the upper cylinder extension is the point where the piston catch ring can snap in to prevent falling out.

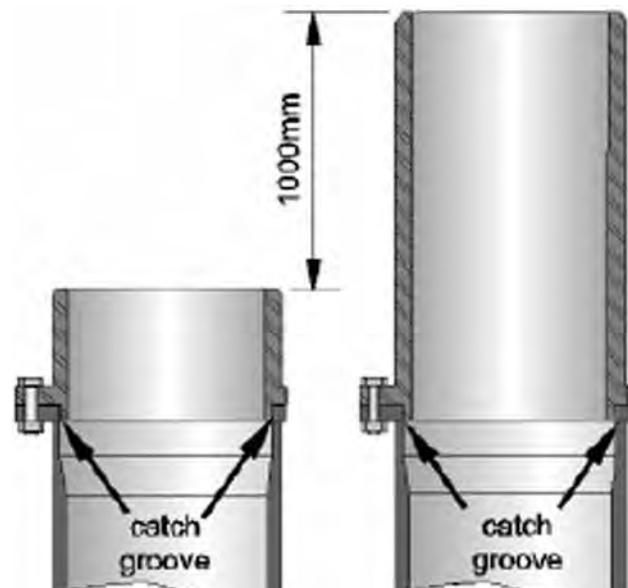

Safety Devices

Bridle

Unless a legislative body specifically asks for a certain type of safety device, the Diesel pile hammer can be secured by other means such as a bridle.

For small hammers up to the D8 exists a solution which connects the tripping device with the upper hammer guiding clips, where a safety bridle like shown is not needed.

! WARNING !

The bridle should never be used to lift the Diesel pile hammer! The Diesel pile hammer should only be moved upward using the tripping device. This is the only way to ensure safe conditions for the Diesel pile hammer.

The bridle must be positioned approximately at the center between the upper and lower guide prior to putting the Diesel pile hammer into operation. The bridle must be adjusted continuously to match the driving progress. **The bridle will be destroyed otherwise!**

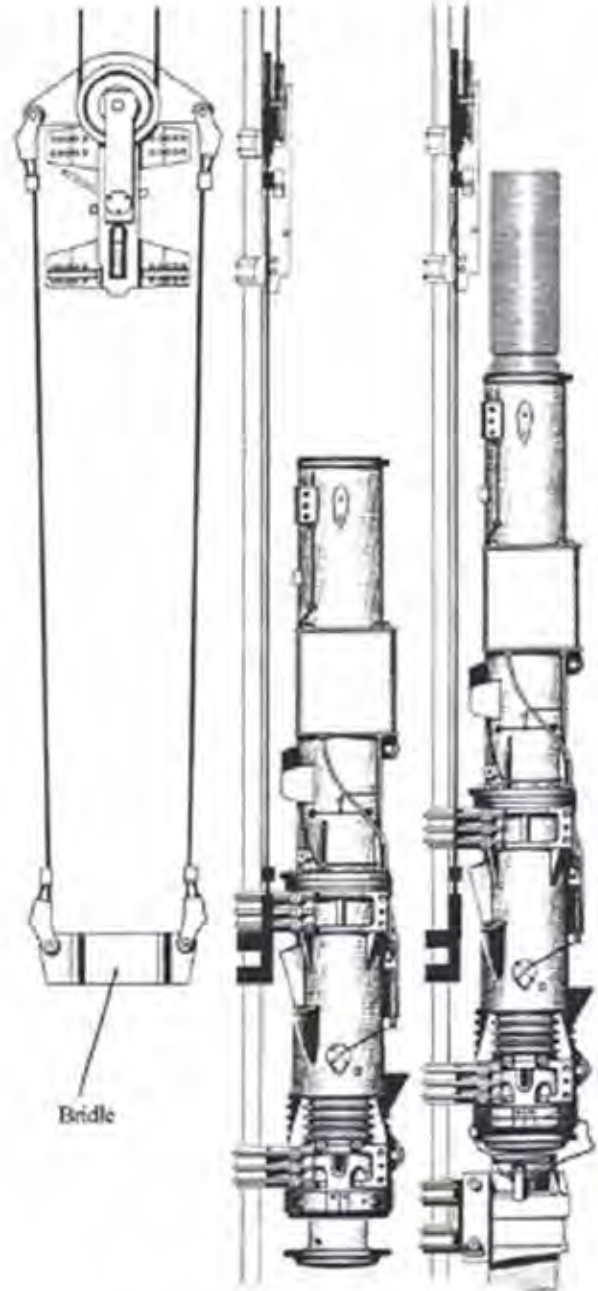

Chapter 6

Starting the Diesel Hammer

1. Filling of Fuel and Lube Tank

! WARNING !

Carefully read and follow Section, "Safety Guidelines" in Chapter 1, prior to putting the unit into operation.

All installation work required to put the unit into operation must be carried out by qualified, authorized and trained personnel.

Diesel hammers are not provided with any fuel/oil types. The fuel and lube tank of all diesel hammers are sized for several hours of continuous running of the machine at maximum performance. Please refer chapter 11, "Applicable Fuel and Lubrication".

The 45° alignment of the tank studs allows filling of the fuel and lubrication tank the horizontal (transport) position or the vertical (working) position of the diesel hammer.

Tank should be filled with caution to insure spill is avoided. The tank is labeled with FUEL and LUBE to prevent improper filling. The filler caps have ventilation holes to allow free flow of fuel and lube out of the tank.

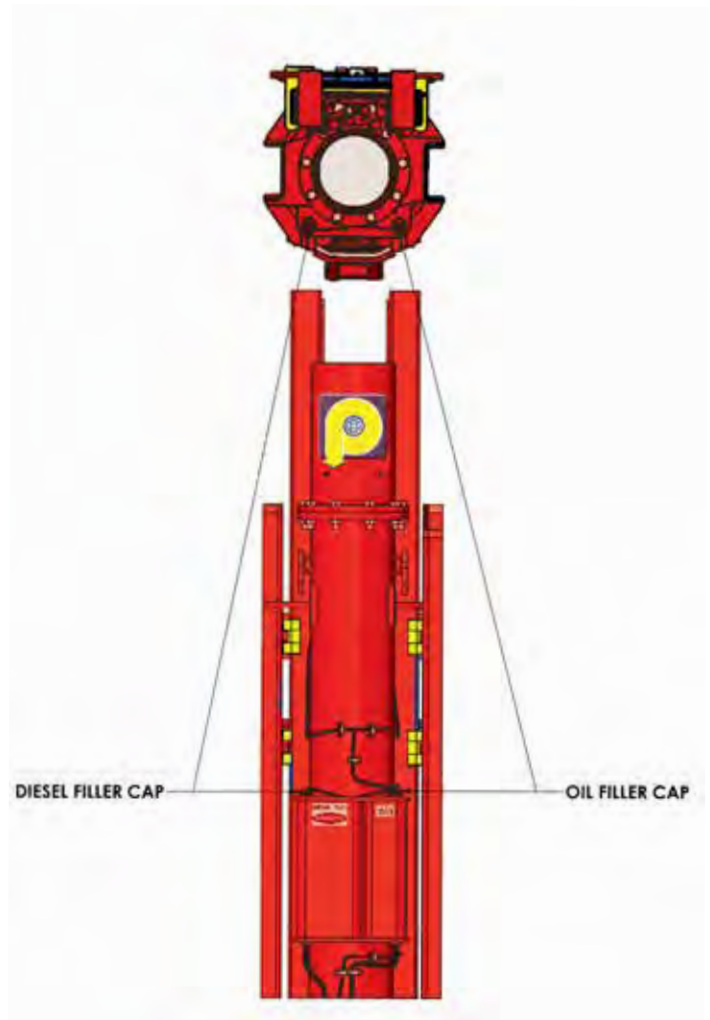

2. Filling of Lubricant Lines w/ Oil

CAUTION

The lubricant lines of the lubricating system must always remain filled with lubricant. Failure to keep lubricant in the system will damage the diesel pile hammer. PPE (Personal Protective Equipment) that is required to perform any and all work shall be provided by your employer to safely perform this task as injuries may result.



The lubricant lines of the lubricant system must be replenished prior to the first putting-into-operation and after repairs to the lubrication system:

- 1.** Lay the diesel pile hammer down in a horizontal position (See Chapter 4, “Transport”).
- 2.** Remove the lubricant lines from the lubricant pump (note: D80 through D280 have multiple lubricant pumps). To do so, loosen the lubricant clamps. Subsequently pull the lubricant lines from the connection fitting.
- 3.** Fill the lubricant lines with motor oil using a squirt can (EO 20, 40 or 50 as a function of the application temperature; see Chapter 9, “Maintenance”). Continue filling the lubricant lines from the bottom with oil, until oil exits at all connection nozzles.

- 4.** Push the lubrication lines back on the respective connection fittings.
- 5.** Tighten the lubricant clamps again. Make sure all lubricant lines are solidly attached to the connection fittings (retighten, if necessary).
- 6.** Put the diesel pile hammer into a vertical position (See Chapter 4, “Transport”).
- 7.** Check the lubricant level in the lubricant tank. The tank must be full.

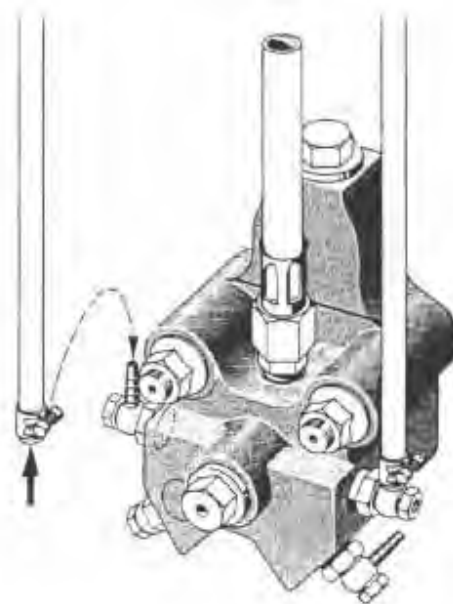

Use Motor Oil SAE 20W or SAE 40W for Lubrication

Fuel Pump Priming

(For New or used dry pumps and Injectors)

- 1) Place fuel and lube into proper tanks.
- 2) Place the fuel pump in the #4 fuel setting.
- 3) Lift ram to within 12" of trip release and hold in that position.
- 4) Pull Stop Valve for 30 seconds to allow air to return to tank.
- 5) Release stop valve.
- 6) With the fuel pump in the #4 fuel setting, pull the right-hand cable or rope several times until resistance is felt.
- 7) If no resistance is felt start again with step #4
- 8) When resistance is felt pull down 5Xs to fill the pressure hose or hoses and injector or injectors.
- 9) Safely lower the ram to the bottom of the starter guides and engage the safety lifting mechanism to lift the entire hammer to start driving operation.



Assembly of Pile Helmet Cushions

The pile helmet cushion transfers the impact from the impact block to the material to be driven. A targeted assembly can dampen the impact to a certain degree (see Chapter 12). Pileco, Inc. recommends a combination plate pile cushion material for several sizes consisting from:

- ½" aluminum cushion
- 1" phenolic cushion
- ½" aluminum cushion

The function of the aluminum plate is taking out the heat from the phenolic cushion plate caused by the impact.

Typical Pileco, Inc. helmet assemblies and helmets you can find online at www.Pileco.com

Assembly

1.

Place the pile helmet cushion of the desired arrangement in the pile helmet. Different cushion material has different dampening properties. Consult Pileco, Inc. if you intend to modify the cushion material.

2.

Set the steel striker plate on top of the cushion. Make sure the contact area of the cushion plate is flat and not bowed, otherwise your cushion material will wear out rapidly.

3.

Guide the supplied cable section through the striker plate padeyes and the padeyes of the helmet

4.

Tighten the cables and secure them with a suitable cable clamp.

5.

If using a primary helmet set the required pile insert in the receptacle.

6.

Slide the helmet or primary helmet in the lead and attach to the Diesel Hammer like shown.

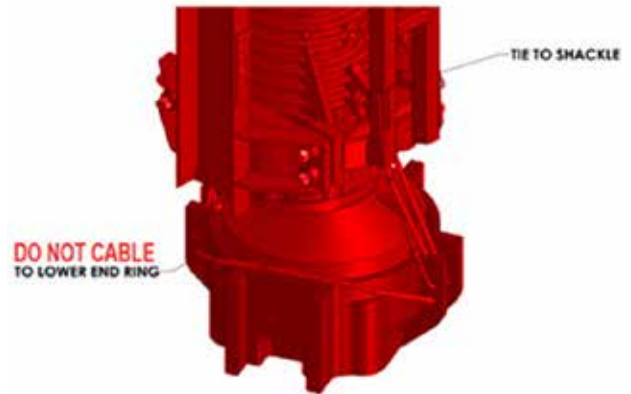

The wire rope connection between the helmet and the Diesel Hammer lifting padeyes (5) must be loose to ensure free movement of the impact block. When the hammer is lifted up the impact block moves out of the cylinder until the inner damping ring stops. In that situation there should be clearance of 0.5" ...1" between the impact block and the striker plate.

! WARNING !

Never use the lifting eyes of the outer end-ring to connect the helmet to the diesel hammer. The lifting eyes should only be used for handling the outer end-ring.

All bolted connections must be tight. Loose bolts can cause serious injuries and property damage.

An incorrect attachment of the pile helmet cushion with the wire rope at the pile helmet can cause the striker plate and cushion to fall out. Danger of an accident may result.

Guiding for the Pile Helmet

CAUTION

The pile helmet cannot be guided at the impact block of the diesel pile hammer. Otherwise, lateral forces may cause damage to the impact block and the cylinder.

- Do not wire rope the helmet to the padeyes of the outer end-ring. The outer end-ring padeyes are designed only for lifting of the end-ring itself during assembly and is not safe for lifting helmets.

- Leave the wire rope long enough to ensure that the impact block can move out completely without tensioning the cable.

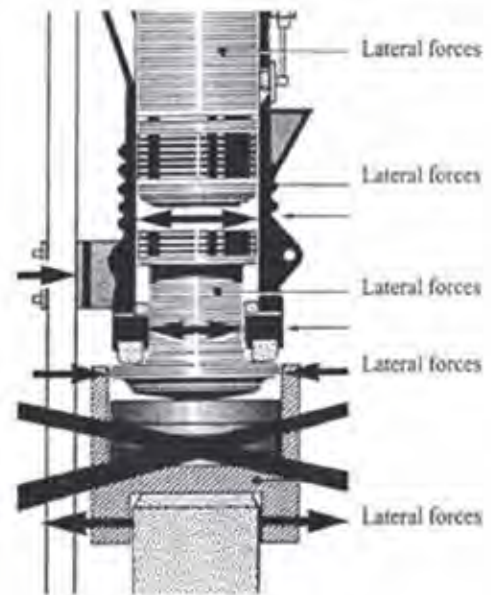

INCORRECT
(Lateral forces cause damage)

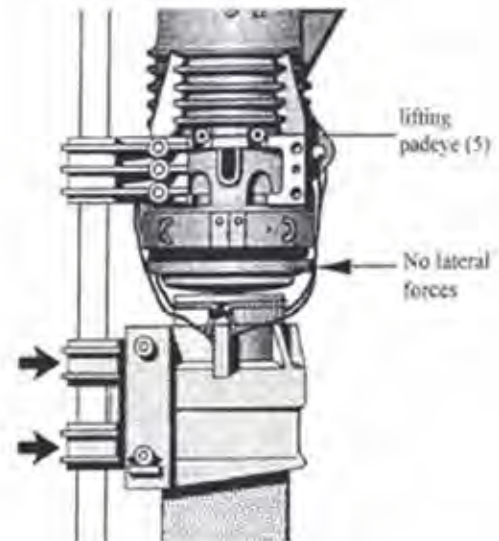

CORRECT
(Guided at the lead)

Lifting of Piles

! WARNING !

Follow the operating instructions of the carrier equipment.

Use only approved wire rope, found in Chapter 4, "Transport" under, "Lifting Cables and Ground Support".

Observe the following information to prevent an overturning of the unit and damage to the lead and material to be driven.

PPE (Personal Protective Equipment) that is required to perform any and all work shall be provided by your employer to safely perform this task. You must wear a life vest when working over water surfaces.



Never pull the material to be driven from the lead tip. This may cause an overturning of the carrier unit or may bend the lead end. Always turn the unit in the direction of the impact point of the material to be driven. The inclined pulling force may cause the unit to overturn.

The material to be driven must always be lifted in such a manner that:

- there is no permanent deformation
- no cracks form in the material to be driven,
- the material to be driven hangs vertically after lifting it.

Never lift piles attached to the hammer using only one line. Always use a separate pile line.

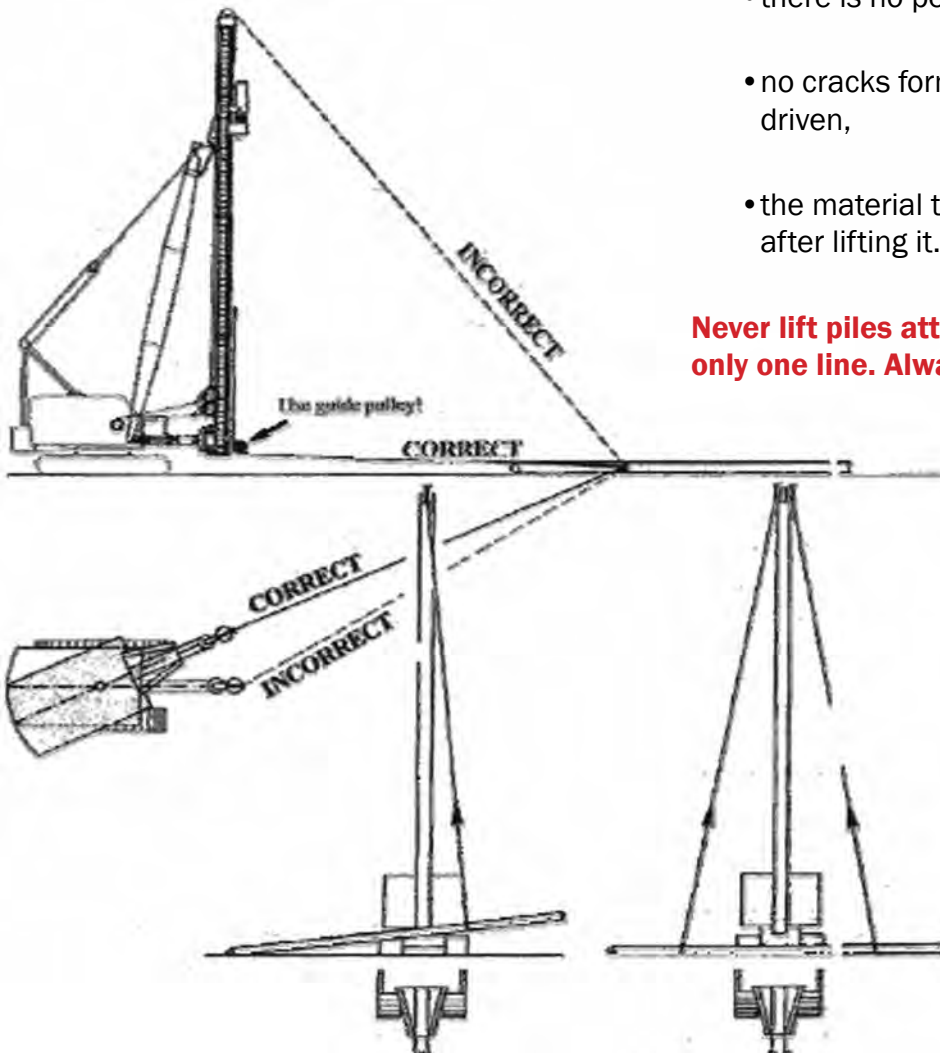

Putting Your Hammer and Helmet In Operating Position

! WARNING !

Observe the operating instructions of the carrier equipment. Equipment to tie down any and all equipment being transported shall be provided by the transport company and be of such to prevent movement of equipment or damage. PPE (Personal Protective Equipment) that is required to perform any and all work shall be provided by your employer to safely perform this task.

Placing the Diesel Hammer in Swinging Lead - Lead Laying on the Ground

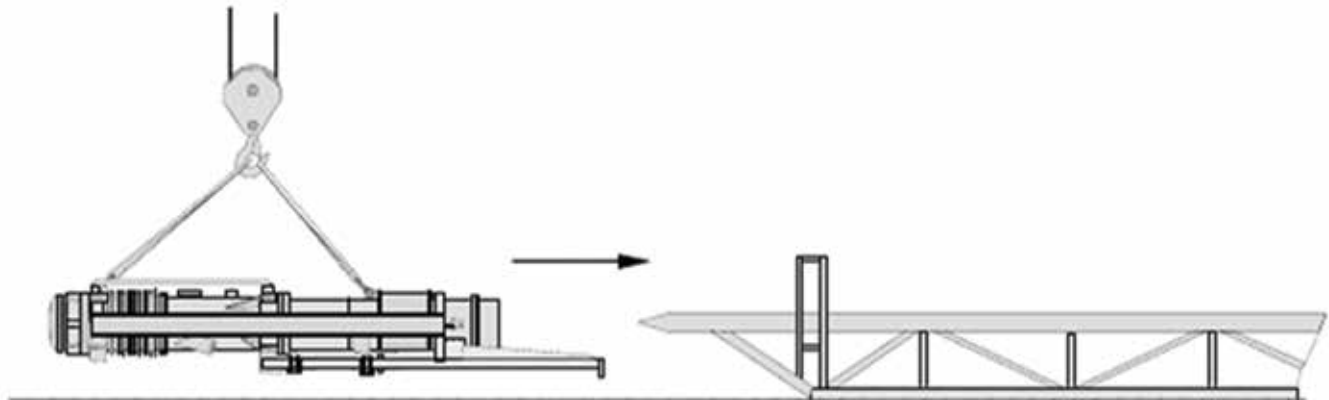

- Diesel Pile Hammers up to the D280 can be equipped with channel guiding.
- The hammer must be slid in the lead from one side.
- Before raising up the lead the starting device and the hammer lifting ears must be connected to the crane hoist line.

Placing the Diesel Hammer in an Offshore Lead-Lead laying on the Ground

- When setting the hammer into the lead pay particular attention to slide the lead guiding carrier and the hammer complete to the guiding bell to prevent uncontrolled sliding when raising the hammer and lead system to upright position
- After setting the hammer into the lead the back side guiding brackets must be bolted on

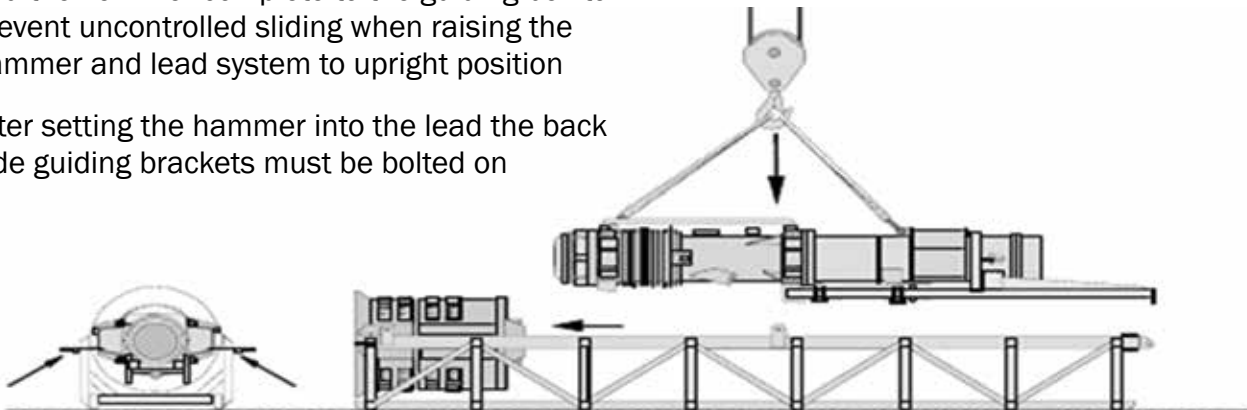

Placing the Diesel Hammer in Fixed Lead-Lead in Vertical Position

- 1.** Mount the tripping device (see Chapter 8, "Shutting Down and Storage") to the lead if not guided directly at the hammer starter guides attached to the hammer.
- 2.** Lift up the tripping device approx. 10ft (3m).
- 3.** Place the diesel pile hammer in front of the lead (horizontal position, See Chapter 4, "Transport").
- 4.** Place the Diesel Pile Hammer on wooden blocks.
- 5.** Remove the transport securing equipment.
- 6.** Place the appropriate slings around the lifting plates (3) and around the hook of the carrier equipment.
- 7.** Carefully pull the diesel pile hammer to a vertical position and place the diesel pile hammer in front of the lead.
- 8.** Install the two lower and one upper guide bracket (22).
- 9.** Lift the diesel pile hammer 3ft (1m). Place the guide brackets (22)
- 10.** Install the second upper guide bracket (22).
- 11.** Place the pile helmet below the diesel pile hammer.
- 12.** Let the diesel pile hammer rest on the pile helmet.

- 13.** Remove the locking screw(s) (piston) and the impact block clamp (See Chapter 4, "Transport").
- 14.** Pull the diesel pile hammer upward until the impact block (19) is fully extended and hangs approximately 2 inches (5 cm) above the pile helmet cushion.
- 15.** Attach the pile helmet to the lower cylinder lifting pad eyes (5) as shown in the illustration. Use the wire rope and wire rope clamps from the tool box.
- 16.** Slowly lift the diesel pile hammer using the tripping device while guiding the pile helmet through the lead.

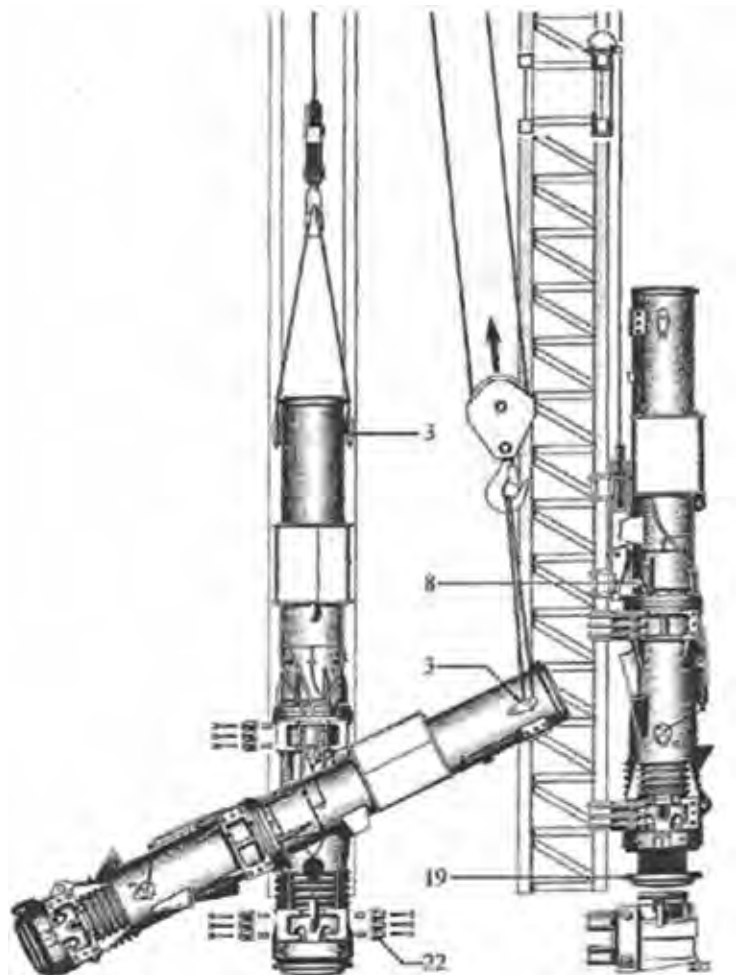

17.

Remove the wire rope slings from the lifting plates (3) and from the hook of the lifting equipment.

18.

Attach both ends of the 230 feet (70 m) long control rope (in the tool box) to the eyelets for the control rope of the fuel pump (12).

19.

Attach the 115 feet (35 m) long rope to the shutoff valve (center eyelet) of the fuel pump (12).

20.

Fill the tank with Diesel fuel (See Chapter 11, “Usable fuels” for alternate fuels). The filling nozzle of the tank indicates “Diesel”. **It is important to use a fuel that is suited for the ambient temperature conditions (see the following table). If this is ignored, the unit may be difficult to start and the fuel lines may become clogged.**

Mixing Ratio Diesel fuel / Regular Gasoline or Engine Oil	
Outside Temperature	Winter Diesel Fuel
-20° C to -30° C -4° F to -22° F	50% / 50%

**Note: regular gasoline tends to pre-ignite.
When subzero Hammer must be tented and heated!**

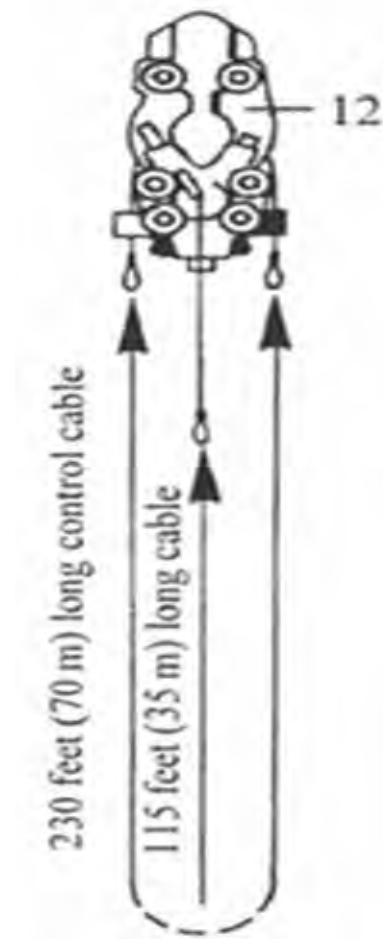

Tripping Device

The Tripping Device is used for auxiliary purposes:

- to lift the diesel pile hammer at the lead,
- to lower the diesel pile hammers at the lead,
- to lift the piston when starting the diesel pile hammer.

The tripping device is operated with the help of a winch on the carrier equipment or hydraulically. Check the tripping device for damage prior to its installation. Use only the tripping devices that are in good working condition.

! D A N G E R !

winch on the carrier equipment or

PPE (Personal Protective Equipment) that is required to perform any and all work shall be provided by your employer to safely perform this task.

You must adhere to proper job regulations.

Installation of the Tripping Device

1. Attach the lower and one upper guide gibs to the tripping device. In U- type leads the tripping device is guided directly at starter guides mounted to the diesel pile hammer.

2. Place the wire rope in the rope sheave or for smaller hammer types connect the wire rope directly to the sheave pin. To do so, you must remove the sheave pin and install it again when the wire rope is positioned. Secure the sheave pin with the safety screw or cotter pin.

3. Lift the tripping device upward and make sure it is smoothly sliding.

4. Attach the rope (in the toolbox) to the lever (A2).

You must keep a distance of at least 13 feet (4 meters) from the diesel pile hammer.

! W A R N I N G !

Lowering the Tripping Device

1. Pull the lever (A2) down to the stop using the rope and keep it taut. This retracts the driving pin (A3) in a vertical position. The tripping device can move past the lifting dogs (6) of the diesel pile hammer.

2. Lower the tripping device to the lower stop (9). The

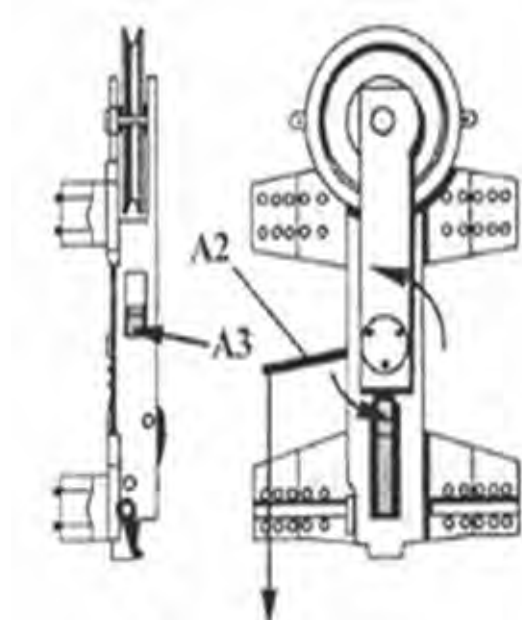
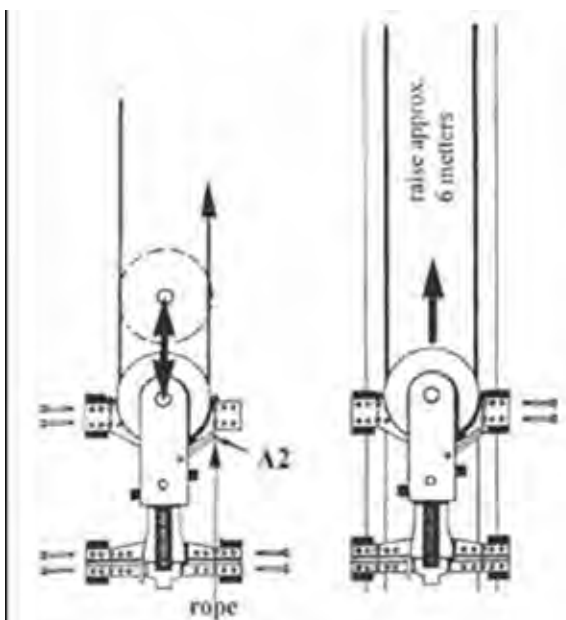

trip cam lever (A5) is pushed upward at the trip cam lever engaging point (9). Pawl (A4) is thus pushed out and into the lifting groove of the piston weight (26).

3. Release the cable at the lever (A2).

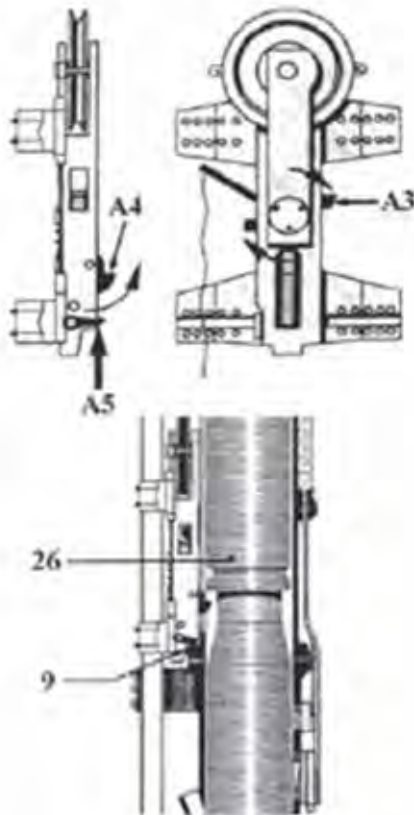

The tripping device must always be lowered to the

! DANGER !

lower stop to ensure that the pawl projects fully and is locked. If

this is omitted, the Diesel Pile Hammer may trip prematurely. The pulley rope must always hang free. Do not tie the pulley rope to the lead or other places. This may cause the Diesel Pile Hammer to fall uncontrollably. Danger to life and risk of a damaging tripping device.

Lift/Lower Diesel Pile Hammer:

- 1.** Lower the tripping device as described above.
- 2.** Slowly pull the tripping device upward using the wire rope hoist. Do not pull on the rope at the lever (A2). During the lifting stage, the surfaces of the

driving pin (A3) grasp below the lifting dogs (6) of the Diesel Pile Hammer. The Diesel Pile Hammer now hangs from the tripping device.

Please be sure the pawl of the starting device is locked under the lifting groove of the piston during lifting of the hammer.

3. Use the hoist to place the diesel pile hammer into the proper position.

4. Set the hammer with helmet assembly on top of a pile.

Lifting the Piston—Start the Hammer

- 1.** Lower the tripping device as described above.
- 2.** Pull the lever (A2) down to the stop using the rope and keep the cable tight. This retracts the driving pin (A3) in vertical position to pass the lifting dogs. After the tripping device passing the lifting dogs the lever A2 can be released to its normal position.
- 3.** Use the hoist line to slowly pull the tripping device upwards. When pulling it upwards, the piston (26) is also pulled upward and automatically released at the upper stop (21).

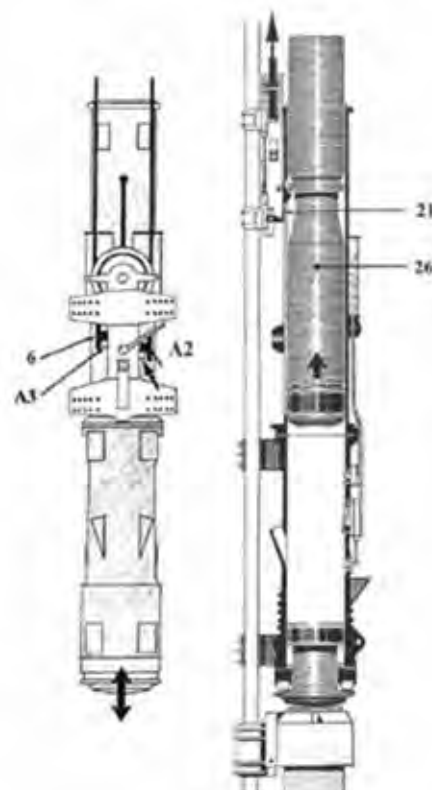

Control of Fuel Supply

The fuel pump determines the energy per blow and thus the drop height of the piston.

The Fuel Pump Has Five Settings:

Settings:	Indicator Pin Position	Fuel Supply
setting I	6 o'clock	49...64%
setting II	8 o'clock	66...77%
setting III	10 o'clock	83...90%
setting IV	12 o'clock	100%
setting 0	4 o'clock	Shut off

The settings can be adjusted by three ropes attached to the fuel pump. For easier use at night identify the ropes with single knots and double knots.

Inspect these ropes carefully as you may need to depend on them to shut down the hammer in the case of an emergency.

The fuel setting can be determined by the position of the dowel pin on the switch shaft of the fuel pump. This dowel pin is normally painted yellow for identification (see chart below).

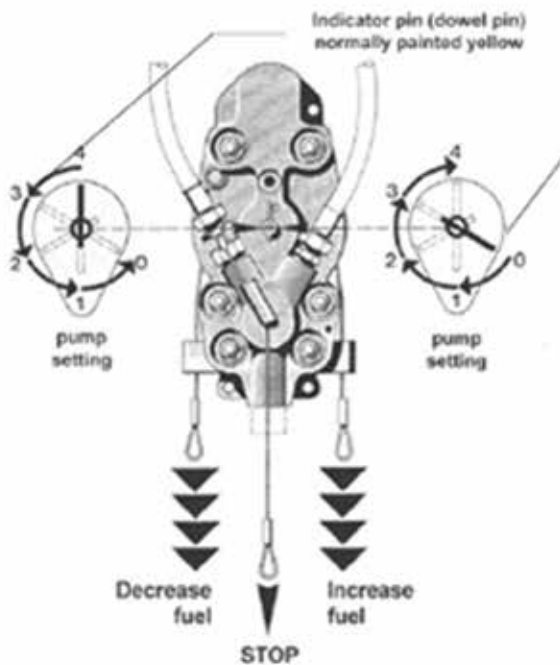

Mode of Operation - Increase Fuel Supply

Pull on the right rope to the stop and release the cable. This switches the fuel pump to the next higher setting. Repeat this step until the desired setting has been reached (to the maximum Setting "4").

Decrease Fuel Supply

Pull on the left rope to the stop and release the cable. This switches the fuel control pump to the next lower setting. Repeat this step until the desired setting has been reached (to a maximum setting of "0").

Fuel Supply Shut-Off

Pull on the center rope to the stop and keep the cable taut until the impact hammer is at rest. This has no effect on the setting of the fuel pump. Should this rope break, you can successfully shut down the hammer in two alternate ways:

- Adjust the fuel pump to the "0" position.
- While in the position "4" (12 o'clock) pull and hold tight the right rope until the impact hammer is at rest. The dowel pin will go to the 2 o'clock. This position is spring loaded. Releasing the rope will cause the fuel pump to return to position "4" (12 o'clock).

Bleed Fuel Pump and Injection Valves

The fuel pump and the injection valves must be bled:

- Prior to the first putting-into-operation
- After repair work
- When the Diesel Pile Hammer fails to operate due to a lack of fuel

! WARNING !

Let the diesel pile hammer cool down fully prior to the bleeding in the event the diesel pile hammer stopped working due to a lack of fuel. Burns and fire may result!

continued....

1. Pull the piston upward until the trip cam lever (A5) of the tripping device is located approximately 8 inches (20 cm) below the release point (21). The fuel flow to the fuel pump will be blocked, when the piston is too low. The fuel flow is released automatically if the piston is above the pump lever and thus is released.
2. Set the fuel pump to Setting “4” (full load).
3. Unscrew the swivel joint at the injection valves (Position 13, Type D6 through D30: only one injection valve) by approximately 2-3 turns. Do not fully unscrew the swivel joint.
4. Activate the pump with the right control rope (dowel pin position 2 o’clock) until fuel without bubbles exits at all swivel joints.
5. Keep the control rope taut and at the same time tighten all swivel joints.
6. Release the control rope.
7. Pull on the center rope for approximately 5 seconds. This opens the shutoff valve. Air can escape into the tank by way of the fuel lines.
8. Release the center rope.
9. Repeat steps 3–8 three times.

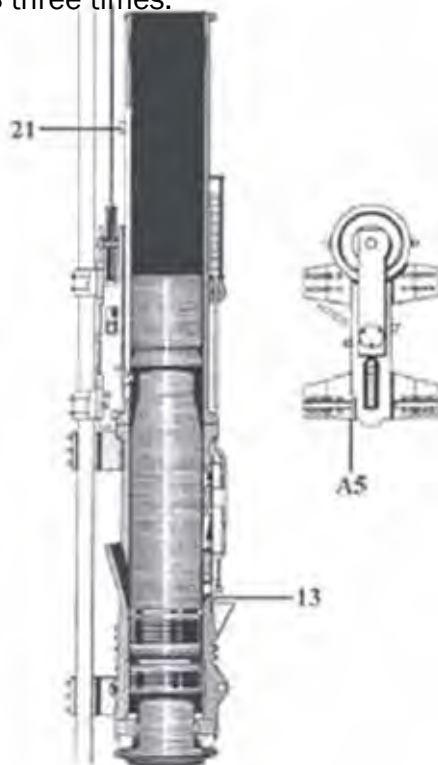

Cleaning of Combustion Chamber

The combustion chamber must be cleaned each day prior to the first startup of the diesel pile hammer. When this is omitted, the lubricant that has accumulated in the combustion chamber would also ignite during starting. The impact hammer may bounce to the catch groove (25) and cause damage.

! WARNING !

The diesel pile hammer must rest on a pile or on the ground (with an appropriate support). It must never rest on a support device. If this is not observed, the support device will be destroyed and the diesel pile hammer will fall uncontrollably to the ground. Maintain a distance of at least 15 feet (4.5 meters) from the diesel pile hammer.

Never stand in front of the diesel pile hammer with an open combustion chamber bolt. Fuel, oil, dirt and material residues will be ejected at a great pressure. This could cause injuries to the eyes or skin as well as burns and poisoning. Proper PPE (Personal Protective Equipment) is necessary.

Take the Following Steps:

1. Set the fuel pump to the setting “0”. To do so, pull the left control cable as often as required.
 2. Remove the blow out plug (16).
 3. Maintain a safe distance from the diesel pile hammer, since dirt and material residues will be ejected at a high pressure.
- Never stand in front of the combustion chamber opening of the diesel pile hammer. Always stand to the side of it.**

4. Raise the piston five times using the tripping device and let the piston drop from the release point. These cold blows allow oil and dirt to escape from the combustion chamber.

5. Screw the plug (16) back in.

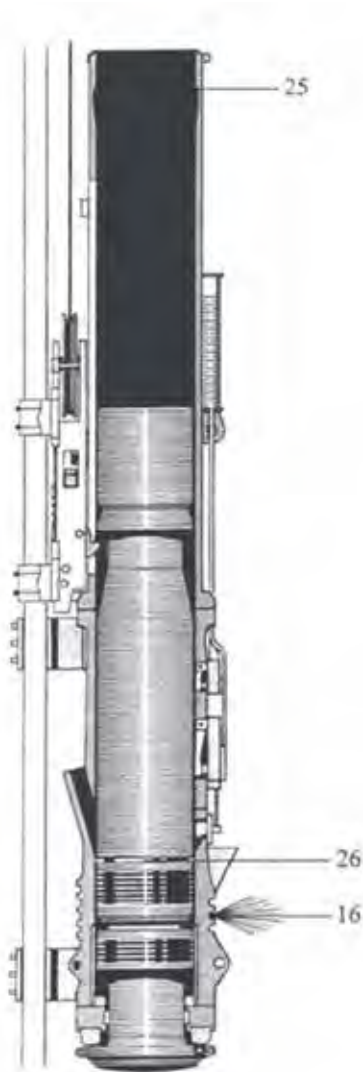

Start and Control



A thorough inspection by a competent/qualified person of the whole driving equipment system prior to putting it into operation. Check the unit for loose screws and bolts, cracks, wear, leaks and possible damage. Check the stability of the unit. Make sure all damages are repaired immediately. Operate the equipment only after all damages have been repaired (See Chapter 9, “Maintenance”).

With the exception of the excavator operator, operator and the foreman in charge of the pile driving, make sure no other person stands within a distance of 1.5 times the lead height, when possible. Sound a horn to warn others of the impending starting of the unit.

The piston should not bounce into the catch groove (#25). The diesel pile hammer must be shut off immediately in this case.

**After the above is Complete,
Operate the diesel hammer ONLY:**

- after checking or replacing the screws used to fasten the upper end ring or upper cylinder extension.
- after checking the catch groove.
- after checking the catch (piston) ring.

You must keep a distance of at least 15 feet (4.5 meters) from the diesel hammer. PPE (Personal Protective Equipment) that is required to perform any and all work shall be provided by your employer to safely perform this task.



Procedure**1.**

Set the fuel pump to the setting “0”. To do so, pull on the left control rope as often as required.

2.

Using the tripping device, pull the piston upward and release it.

3.

For a pre-driven pile: Set the fuel pump to the setting “2” after the first blow. To do so, pull the right control rope twice. For a newly placed pile: Set the fuel control pump to the setting “3” after the first blow. To do so, pull the right control cable three times.

4.

Continuously adjust the fuel injection quantity by pulling the control cables. Do not increase the injection quantity faster than one step per stroke.

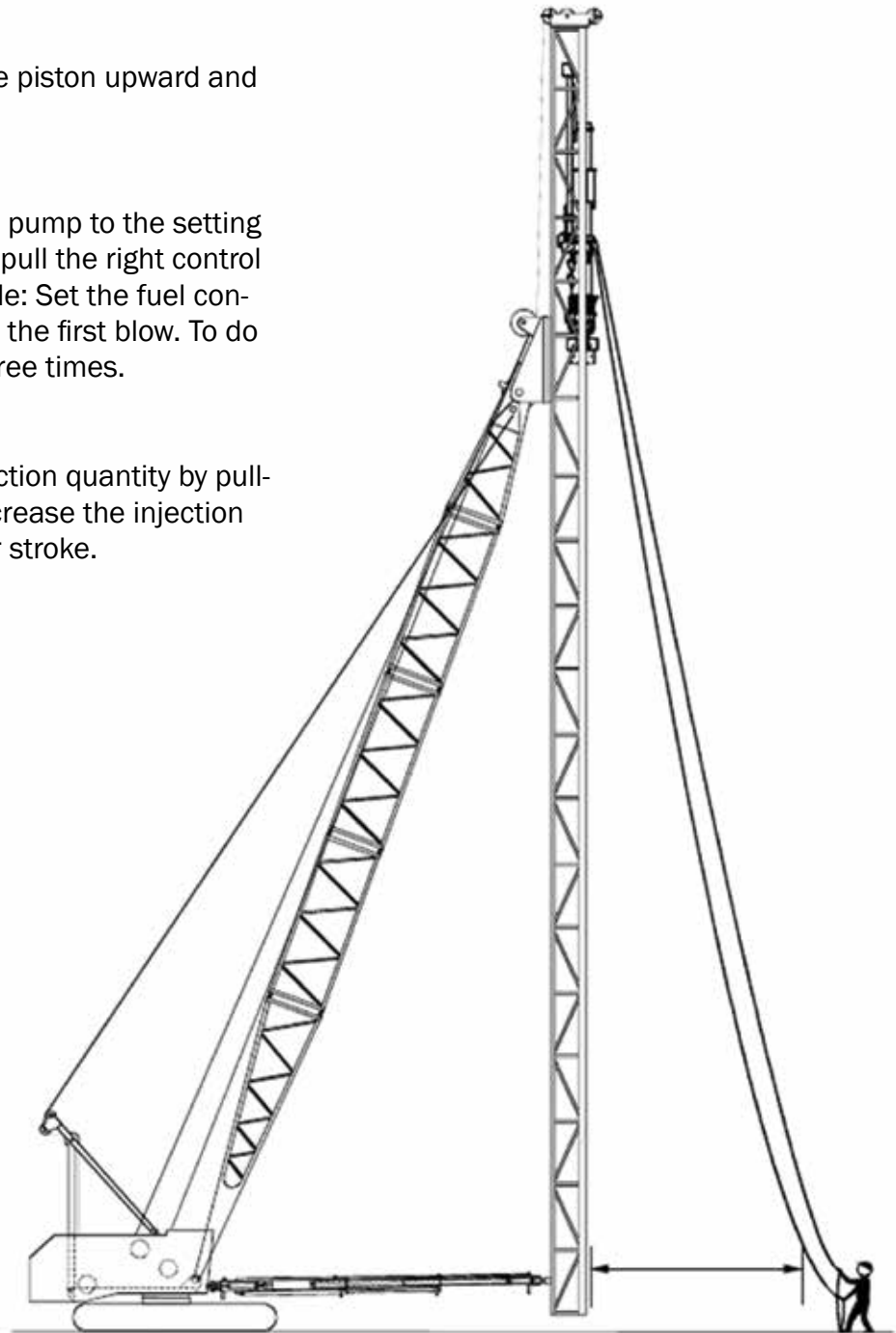

**at least 15 ft.
(4.5 meters)**

Chapter 7

Operations

General Information

Follow all safety measures described in Chapter 2. Operate the diesel pile hammer and lead only when they are in a perfect technical condition. Particularly the guiding components and tripping device should show no signs of wear.

PPE (Personal Protective Equipment) that is required to perform any and all work shall be provided by your employer to safely perform this task.

Immediately halt the pile-driving operation when a dangerous situation develops (e.g., when unauthorized persons enter the danger zone or in the event of damage). Operate the diesel pile hammer only after the dangerous situation has been taken care of.

Do not carry out any repair or maintenance work on a moving diesel pile hammer.

! WARNING !

1.

Never start the diesel pile hammer unless it is resting on a pile or a specially prepared test stand.

2.

Never start the diesel pile hammer with the impact block hanging out. The impact of the piston will transmit directly to the cylinder outer end-ring resulting in damage of outer end-ring and lower cylinder. A stuck impact block prevents the cylinder from freely dropping on the impact head unit (possibly due to defective damping rings).

3.

Never start a Diesel pile hammer which has been disconnected from the lead or which is resting on a skid, etc. The support device will be destroyed and the diesel pile hammer will come crashing down causing an accident.

4.

Never drive piles eccentrically. This may cause damage to the cylinder and guide components as well as damage and vibrations to the material to be driven. The center line of the material to be driven must be in line with the center line of the diesel pile hammer. This is necessary to avoid jarring blows. Jarring blows could cause such as but not limited to the following:

- cracks in and deformation of the cylinder,
- vibrations in and damage to the material to be driven,
- directional deviation for the material to be driven.

Remedy: Use a pile helmet that is guided at the lead and matches the pile profile. Use a pile helmet cushion selected in an optimal manner with respect to the material to be driven and to the blow energy. When it is impossible to guide the pile helmet at the lead, it will be necessary to hold the material to be driven at the lead with at least one pile guide.

5.

Increased wear in the guide components, is caused by rebounding impacts. This is caused by driving eccentrically. Very hard driving of relatively elastic piles (H-beams, spiral welded thin wall pipe piles) will lead to damage of the diesel pile hammer especially the rubber rings.

6.

Refusal:

Stop the Diesel pile hammer if the penetration rate is higher than 10 blows per inch. Higher blow rates are possible, but it causes higher wear of the diesel pile hammer. **Pileco, Inc. cannot warranty parts if it is obvious that the chosen hammer for the job was too small.**

7.

The piston should not bounce into the catch groove. If so this may damage the catch ring, catch groove and attachment screws. The safety of the diesel pile hammer is thus no longer ensured

8.

The combustion chamber must be cleaned each day by a trained worker prior to the first start-up of the diesel pile hammer. When this is omitted, the lubricant that has accumulated in the combustion chamber would also ignite during starting. The impact hammer may bounce to the catch groove and cause damage.

9.

Make sure the allowable batter is not exceeded when driving batter piles. Make sure the diesel pile hammer is maintained regularly and properly.

10.

When using a bridle, the bridle must be adjusted continuously to the pile driving progress. The bridle will be destroyed otherwise. The safety against a fall is no longer ensured.

Deviations from the original directions of the material to be driven can also occur under the best conditions. Accordingly, it will be necessary for the foreman in charge of the pile driving work to continuously monitor the pile driving phase and to have the lead corrected, when required.

Shutting Off:

Pull the center rope (at the shut off valve) and keep it tight until the piston is completely at rest. The diesel pile hammer can also be shut off by setting the fuel control pump to the setting "0". To do so, jerk the left control rope as often as required.

Blow Energy

Standard Fuel Pump

The blow energy is adjusted to the respective blow conditions by controlling the fuel supply. The blow energy of the respective type at different settings can be taken from the table shown below.

Type	Injection Quantity at setting 4 100% ±10%	Injection quantity (%) and blow energy* Nm (ft. lbs.)			
		setting 4 100%	setting 3 83...90%	setting 2 66...77%	setting 1 49...64%
D8-52	1.75 cm ³ /stroke	25,400 Nm 18,760 ft. lbs.	21,080 Nm 15,570 ft. lbs.	16,900 Nm 12,464.8 ft. lbs.	12,853 Nm 9,480 ft. lbs.
D12-42	2.10 cm ³ /stroke	40,460 Nm 29,840 ft. lbs.	33,580 Nm 24,760 ft. lbs.	26,700 Nm 19,690 ft. lbs.	20,470 Nm 15,100 ft. lbs.
D19-42	3.54 cm ³ /stroke	57,600 Nm 42,480 ft. lbs.	47,810 Nm 35,260 ft. lbs.	38,015 Nm 28,035 ft. lbs.	29,160 Nm 21,510 ft. lbs.
D25-32	3.90 cm ³ /stroke	79,040 Nm 58,300 ft. lbs.	71,136 Nm 52,470 ft. lbs.	58,490 Nm 38,830 ft. lbs.	40,010 Nm 29,510 ft. lbs.
D30-32	4.70 cm ³ /stroke	94,890 Nm 69,990 ft. lbs.	85,400 Nm 62,990 ft. lbs.	70,220 Nm 51,790 ft. lbs.	48,040 Nm 35,435 ft. lbs.
D36-32	5.65 cm ³ /stroke	113,820 Nm 83,950 ft. lbs.	94,470 Nm 69,680 ft. lbs.	75,120 Nm 55,410 ft. lbs.	57,620 Nm 42,500 ft. lbs.
D46-32	7.15 cm ³ /stroke	145,450 Nm 107,280 ft. lbs.	120,720 Nm 89,040 ft. lbs.	96,000 Nm 70,805 ft. lbs.	73,650 Nm 54,320 ft. lbs.
D50-32	7.82 cm ³ /stroke	158,600 Nm 116,643.4 ft. lbs.	131,700 Nm 96,814 ft. lbs.	104,700 Nm 76,985 ft. lbs.	81,200 Nm 59,727 ft. lbs.
D62-22	8.70 cm ³ /stroke	219,150 Nm 161,640 ft. lbs.	181,895 Nm 134,160 ft. lbs.	145,735 Nm 107,490 ft. lbs.	107,380 Nm 79,200 ft. lbs.
D70-32	9.60 cm ³ /stroke	246,800 Nm 182,074 ft. lbs.	205,300 Nm 151,452 ft. lbs.	160,900 Nm 118,739 ft. lbs.	120,700 Nm 89,043 ft. lbs.
D80-23	10.50 cm ³ /stroke	267,300 Nm 197,150 ft. lbs.	239,770 Nm 176,840 ft. lbs.	196,730 Nm 145,100 ft. lbs.	171,080 Nm 126,180 ft. lbs.
D100-13	12.50 cm ³ /stroke	334,060 Nm 246,390 ft. lbs.	299,650 Nm 221,010 ft. lbs.	257,895 Nm 190,210 ft. lbs.	213,790 Nm 157,685 ft. lbs.
D125-32	15.5 cm ³ /stroke	384,860 Nm 283,860 ft. lbs.	338,670 Nm 249,800 ft. lbs.	288,645 Nm 212,895 ft. lbs.	230,910 Nm 170,310 ft. lbs.
D138-32	17.5 cm ³ /stroke	460,900 Nm 340,000 ft. lbs.	410,300 Nm 302,600 ft. lbs.	354,900 Nm 261,800 ft. lbs.	274,800 Nm 217,600 ft. lbs.
D160-32	21.0 cm ³ /stroke	502,100 Nm 370,350 ft. lbs.	441,850 Nm 325,910 ft. lbs.	376,575 Nm 277,760 ft. lbs.	301,260 Nm 222,510 ft. lbs.
D180-32	23.0 cm ³ /stroke	601,300 Nm 443,500 ft. lbs.	535,200 Nm 394,700 ft. lbs.	463,000 Nm 341,500 ft. lbs.	368,300 Nm 271,640 ft. lbs.
D225-22	17.0 x 2 cm ³ /stroke	768,400 Nm 564,973 ft. lbs.	637,700 Nm 468,928 ft. lbs.	545,500 Nm 401,131 ft. lbs.	399,500 Nm 276,837 ft. lbs.
D250-22	18.0 x 2 cm ³ /stroke	858,600 Nm 631,352 ft. lbs.	712,700 Nm 524,022 ft. lbs.	609,600 Nm 448,260 ft. lbs.	455,100 Nm 334,617 ft. lbs.
D280-22	19.0 x 2 cm ³ /stroke	935,900 Nm 688,145 ft. lbs.	832,900 Nm 612,449 ft. lbs.	692,500 Nm 509,227 ft. lbs.	486,700 Nm 357,835 ft. lbs.

You must be aware of the following:

- The given values are measured values. Deviations are possible between Diesel pile hammers of the same type.
- The given blow energy is obtained only for vertical driving work. For batter piles, the blow energy is reduced as a function of the batter (See Chapter 5, “Conversion for Batter Piles”).

Hydraulic Controlled Fuel Pump

The hydraulic controlled fuel pump on the diesel hammer is continuous adjustable from zero to maximum injection volume. The maximum injection volume is the same like on the conventional injection pumps.

The system consists of:

- hydraulic control cylinder inside the fuel injection pump
- hydraulic hose
- hydraulic hand pump with reservoir, pressure gauge and quick relief valve

Applying hydraulic pressure to the control cylinder inside the fuel pump adjusts the fuel injection volume to a larger amount. At a hydraulic hand pump pressure of 275 to 375 psi the maximum hammer performance should be reached.

That depends on...

- length and diameter of used hydraulic hose
- pile type, pile driving and soil conditions
- outside temperature and weather conditions

Shutting off the diesel pile hammer can be obtained by:

- pulling the line of the shut off valve at the fuel pump
- opening (or pushing) the quick relief valve gauge pressure (psi)

- The injection quantity is not exactly proportional to the blow energy, because the fuel is burned at different degrees of efficiency. For example: 50% of the injection quantity does not reduce the blow energy by exactly 50% but for simplification purpose this assumption can be done.

Hydraulic Controlled Fuel Pump



Hydraulic Hand Pump w/ Manifold

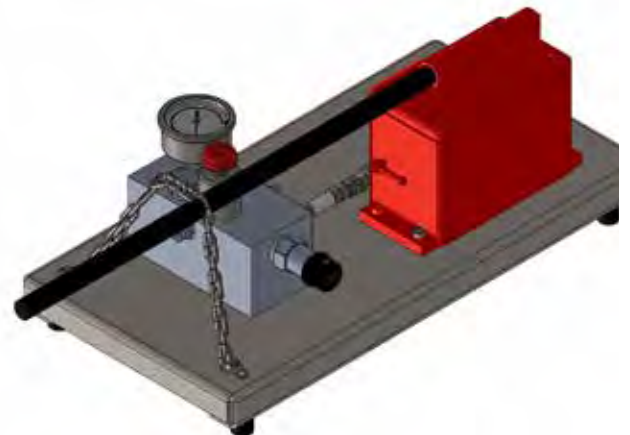

Start of Diesel Pile Hammer

Offshore Lead with bridle bar and trip sling

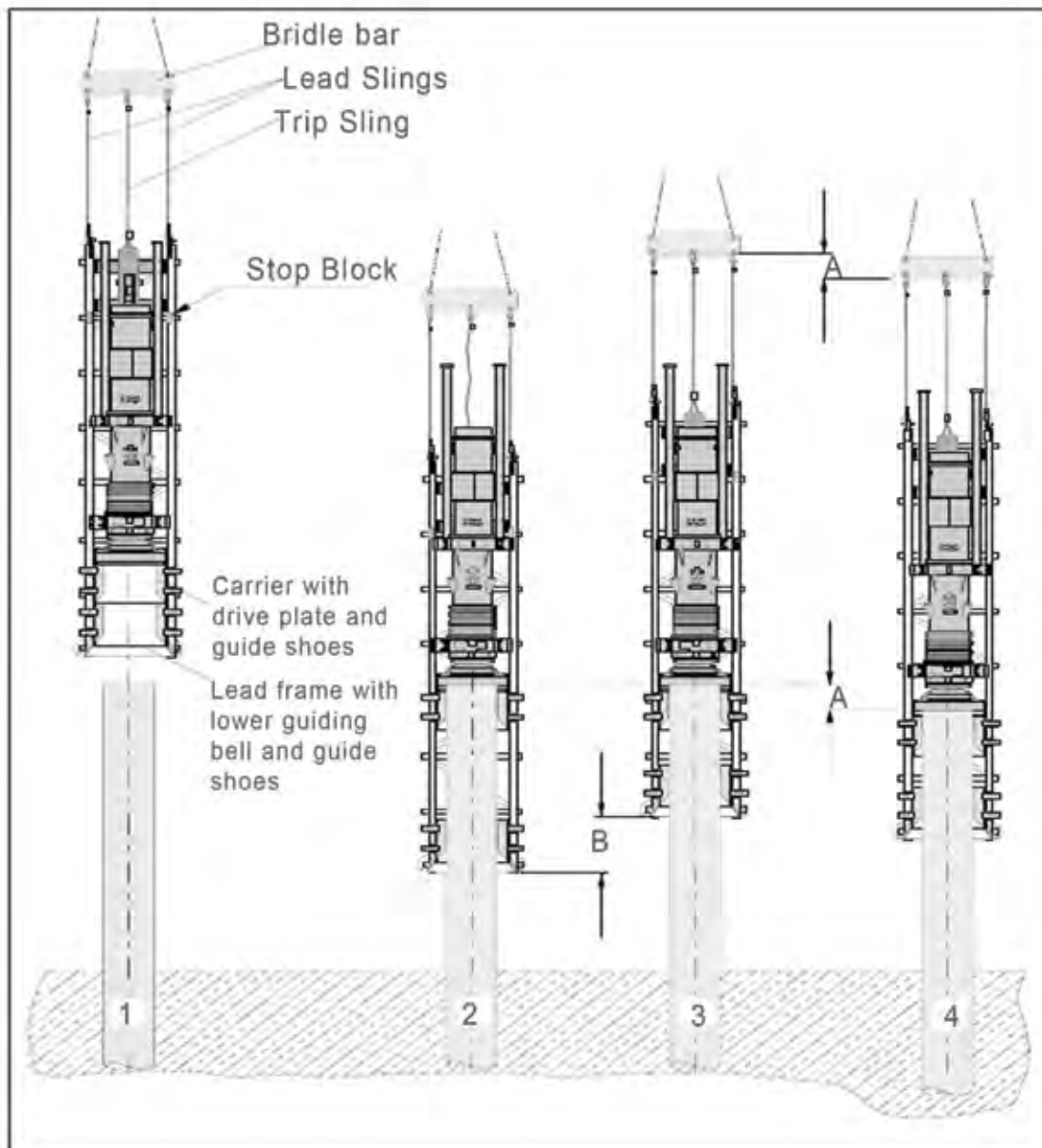

A economic solution for jobs where fixed or swinging leads cannot be used is the Pileco, Inc. offshore type lead system.

Requirements Are:

- Pre driven piles or piles guided in a template or jacket
- The lead size must be chosen to the pile and hammer size, within a range the lead can adapt to the pile size with guide shoes

Procedure for starting the hammer using bridle bar and trip sling:

1. Lifting the lead with hammer over the pile
2. Lowering the lead down until the hammer guides run against the stop block at the lead rails. Lowering the lead further down until the trip is sled down to the lower position at the hammer and the trip lever engages
3. Lift up the lead by distance B. The trip will slide up at the starter guides until it reaches the release point where the piston is released and the diesel hammer starts. The minimum distance never should be less than 1 ft, otherwise there is a risk of damaging the lead. The pile can “run” and the diesel pile hammer impact can be transferred directly to the lower guiding bell, the lead frame and also to the crane boom. The cable length for lead and tripping device are designed in a way that keeping the minimum distance is possible.
4. As soon as the diesel pile hammer started the lead must be lowered continuously with the progress of the pile penetration (A) to keep at least the minimum required distance (1ft) between carrier and lower guiding bell.

Starting the Hammer Using a Hydraulic Start Cylinder

Pileco, Inc. offers the solution for a hydraulic starting device for all diesel pile hammers allowing a better controlling of the start procedure. The hydraulic start is a common attachment for diesel hammers to enable an easy start. The advantage of the hydraulic start is especially with heavy diesel hammers is preventing the back slash into the crane boom when releasing the piston weight

The hydraulic cylinder can be mounted to the starter guides or the lower cylinder of the diesel hammer. A safety valve assures **that the tripping device stays in the upper position while running the diesel hammer.**

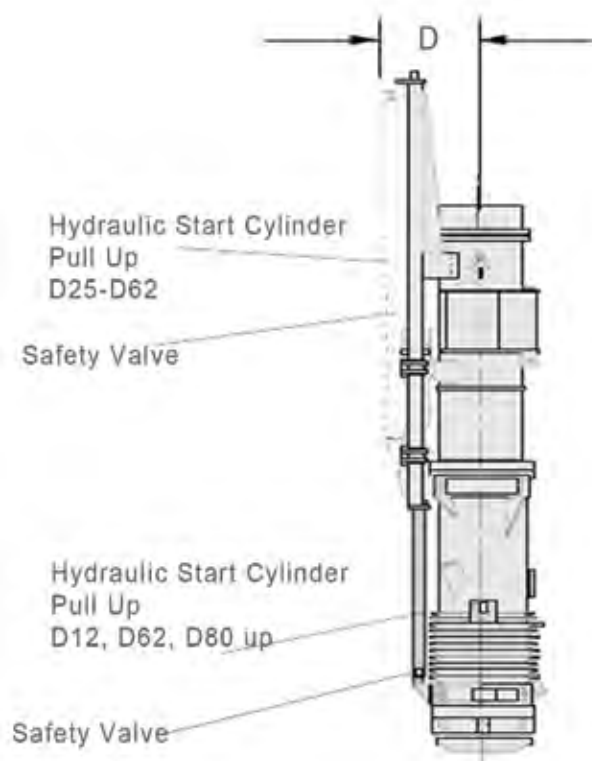

PULL UP –version

After positioning the lead and the diesel hammer on the pile (3) the hydraulic cylinder must be extended completely to lower the tripping device completely down and engage. Retracting the hydraulic cylinder will lift the piston of the diesel pile hammer up to the release point.

CONTINUE TO RETRACT THE HYDRAULIC CYLINDER TO THE END POSITION !

After starting the diesel pile hammer the tripping device must remain in the upper position. Switch off the power pack to prevent accidentally lowering the tripping device. A safety valve ensures the position of the tripping device if ever a hydraulic hose should burst.

! WARNING !

Lowering the tripping device while running the diesel hammer will cause major damage at the diesel hammer!

PUSH UP –version

After positioning the lead and the diesel hammer on the pile (3) the hydraulic cylinder must be retracted completely to lower the tripping device completely down and engage. Extending the hydraulic cylinder will lift the piston of the diesel pile hammer up to the release point.

CONTINUE TO EXPAND THE HYDRAULIC CYLINDER TO THE UPPER END POSITION!

After starting the diesel pile hammer the tripping device must remain in the upper position. Switch off the power pack to prevent accidentally lowering the tripping device. A safety valve ensures the position of the tripping device if ever a hydraulic hose should burst.

! WARNING !

Lowering the tripping device while running the diesel hammer will cause major damage at the diesel hammer.

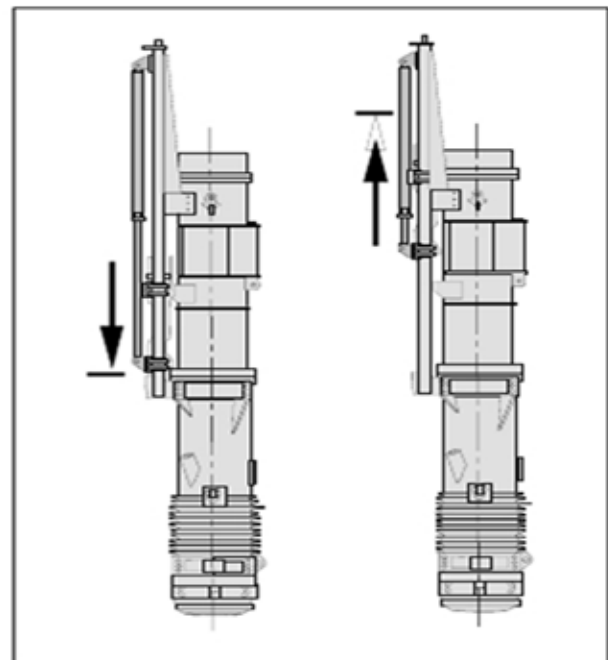
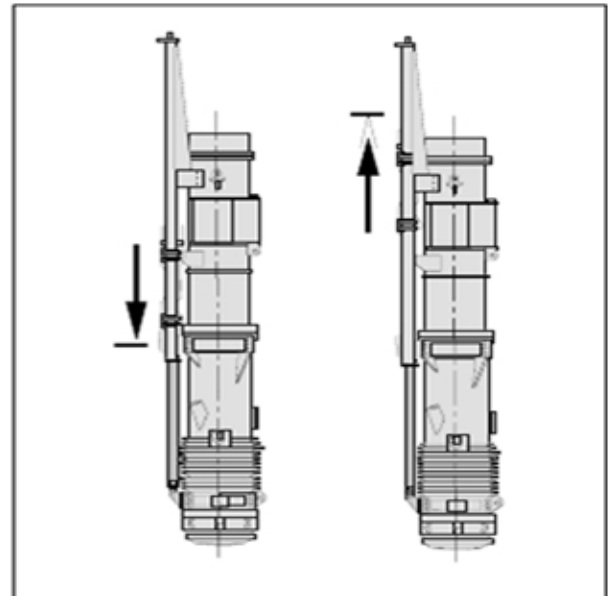

Hydraulic Starting Device and Power Pack

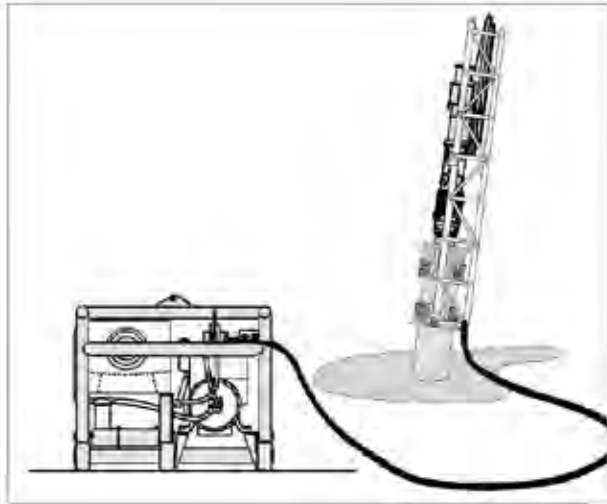

Specification Engine

- DEUTZ F3L1011F (air cooled)
- Output 55 hp at 2300 rpm
- Fuel capacity : 24 US gallon (93 ltr.)

Specification Hydraulic System

- Single stage gear pump, P31 497 GE
- Max. operation pressure: 2800 psi
- Oil flow see chart

Hydraulic Reservoir

- approx. 40 US gallon (approx. 150 ltr.)

Hydraulic Valve

- directional control open center spool valve with pressure relief up to 3000 psi

Dimension: length: 64"
width: 52"
height: 51"

Weight approx.:

2200 lbs

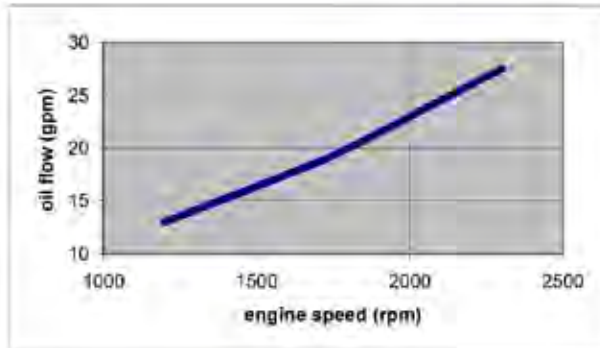

Technical data for hydraulic start of the Pileco Diesel Hammer

In the table below is shown the theoretical time to pull up the piston 80" (2m) and the time to move the tripping device back to start position. The values are based on the max. oil flow (14 gpm) of the powerpack shown above. Larger powerpacks with increased oil flow allow a faster working cycle.

Time (s) for 80" stroke	D19....D62	D80 / D100		D125 / D160
	Pulling version	Pulling version	Pushing version	Pushing version
Trip upwards	14	35	42	51
Trip downwards	19	42	35	32

Chapter 8

Shutting Down and Storage

Shutting Down and Storage

Shutting down and leaving in lead

! WARNING !

The Diesel hammer may be left in the lead for a temporary shutoff. Always let the Diesel hammer rest on the material to be driven or set to the ground.

Make sure the carrier unit exhibits a sufficient stability. Take into account a change in the weather (rain, storm). Danger of overturning!

Do not touch the Diesel pile hammer shortly after operation. Danger of burns! Let hot components cool for a sufficient period.

You must wear a hard hat, safety gloves, safety boots and appropriate work clothes. You must wear a life vest when working above a water surface.

Block the danger zone of 1.5 times the lead height! Use warning signs to prevent anyone from entering this zone. Observe local regulations for the blocking of job sites.

Removal from the Lead

When the Diesel pile hammer will not be operated for several days, it will be necessary to remove it from the lead.

! WARNING !

Follow the operating instructions of the carrier equipment. Do not touch the Diesel pile hammer shortly after operation. Danger of burns! Let hot components cool down for a sufficient period.

Proceed as indicated below:

- 1. Let the Diesel pile hammer rest on the material to be driven or on the ground.**
- 2. Let the Diesel pile hammer cool down completely.**

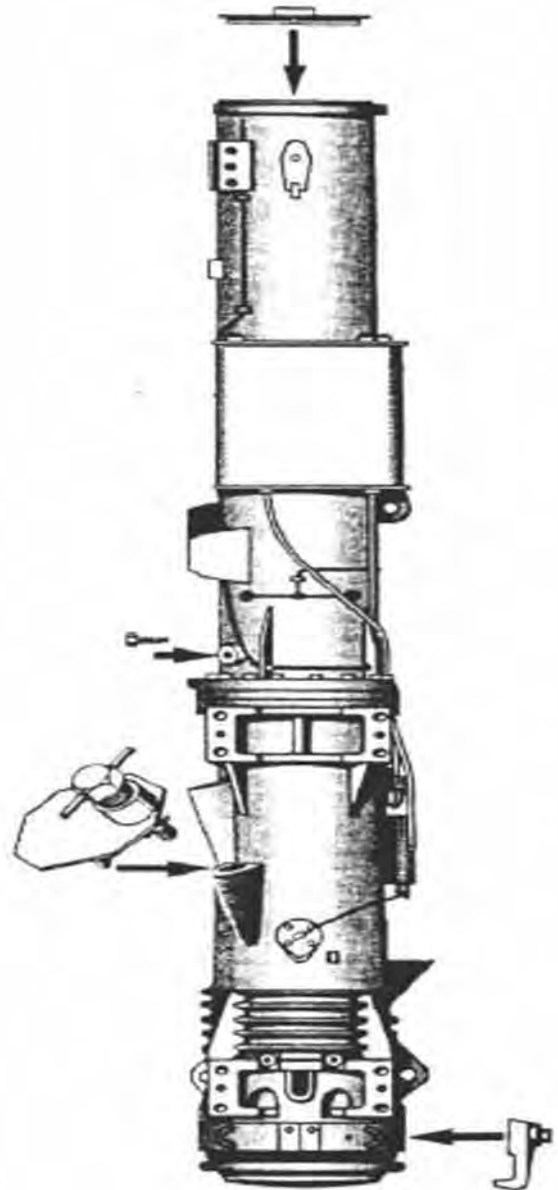

3. Install the piston locking screws, piston safety, protective hood and exhaust covers (See Chapter 4, "Transport safety").
4. Remove the ropes from the fuel control pump.
5. Taking the hammer out of the lead. Put the hammer a side in reverse procedure like described in chapter 6
6. Set the hammer on a stable plain ground, if necessary use 3" thick wood planks.
7. Remove the steel cable loops from the lifting ears (3)
8. Put the carrier equipment out of operation (See operating instructions for the carrier equipment).
9. Secure the job site in accordance with local regulations for the blocking off of job sites.



! WARNING !

Storage

Let the Diesel pile hammer fully cool down prior to storage. **Danger of burns and fire!**

You must wear safety gloves, safety boots and suitable work clothes. A suitable breathing apparatus must be worn, when required.

Fuel and lubricants are extremely flammable and explosive under certain conditions! Drain the tanks only in a well ventilated area! No smoking or work with open flames or sparks is allowed during the draining of the tanks and in storage areas for fuel, ether and lubricants!



The following points must be observed when storing the Diesel pile hammer:

1. Check the Diesel pile hammer for damages and wear. Have the necessary repairs carried out immediately. This prevents the work from being forgotten.
2. Check the tanks and lines of the Diesel pile hammer for leaks and a solid fit.
3. Drain the tanks (fuel, oil).
4. Clean the filters.
5. Close the drain openings of the fuel pump with a rubber plug.
6. Remove and clean the piston, impact block, upper and lower cylinder section. Check all connection elements for a solid fit.
7. Clean and check the tripping device as well as the guide components of the Diesel pile hammer and of the tripping device for damage and wear .
8. Clean and check the pile helmet, attachment cables, pile helmet cushion and accessories (bridle, support devices) for damage and wear. Pile helmet cushions made of wood do not store well and are thus not to be stored for a long time.
9. Check the tool box and determine its completeness and the condition of the parts. Replace missing or unusable parts with new parts. Check the control cables for the tripping device and fuel pump for damage and wear (replace, if necessary).
10. Check the condition and completeness of protection devices and personal safety equipment as
 - Protective clothing, hard hat, safety gloves and safety boots
 - Safety goggles and ear plugs,
 - Lifesaving vest
 - Height safety devices

The personal safety equipment must meet local safety regulations!

continued....

11. Prepare the Diesel pile hammer for storage (See “Laying-up”).

12. Protect the Diesel pile hammer against the effects of the weather. Cover the Diesel pile hammer and all accessories (Do not use plastic foil or other coated materials). If possible, storage the Diesel pile hammer in an unheated and dry room exhibiting minimal temperature changes. Do not store the Diesel pile hammer in direct sunlight.

Laying-up – long time storage

The protective effect is very much a function of the thickness and viscosity (ductility) of material used. We recommend the use of Moly Grease 126 EP#2; it is a thick grease that you can apply with a rag or brush.

1. Disassemble the Diesel pile hammer. Observe the installation information indicated in Chapter 10, “Servicing and Troubleshooting”.

2. Remove all dirt and rust from all components. Replace worn or damaged parts.

3. Touch up the paint. Let the fresh paint dry.

4. Run a corrosion protection oil through the fuel and lubricant pump.

5. Lubricate the tripping device and subsequently apply a rust protection oil to it by brush.

6. Apply a rust protection oil by brush to the guide parts of the Diesel pile hammer and the tripping device.

7. Spray the tank inside with a rust-inhibiting oil. Then solidly close the tanks.

8. Carefully apply grease such as Moly Grease 126

EP#2 by brush to all unpainted parts (including the holes in the end ring, upper and lower cylinder)

9. Assemble the Diesel pile hammer and all transport safety devices. Follow the assembly information in Chapter 10, “Servicing and Troubleshooting” as well as Chapter 4, “Transport Safety Devices”).

10. Apply a rust-inhibiting oil to all metal tools in the tool box.

Chapter 9

Maintenance

Maintenance
! DANGER !

Maintenance work must be carried out by qualified authorized personnel!

Place the Diesel pile hammer out of operation prior to carrying out any maintenance work. Make sure the unit cannot be put into operation by other persons during maintenance work. **Danger to life!**

Do not touch the Diesel pile hammer after operation! Danger of burns! Let hot components cool down sufficiently!

You must wear a hard hat, safety gloves, safety boots and suitable work clothes. You must wear a life vest when working above a water surface.

Diesel Hammer Fuel and Lubricant Recommendations

Standard Hammer Operation

Fuel: #2 Diesel

***Lube Oil:**

- SAE 5W for temperatures -10° to 10° F
- SAE 10W for temperatures 0° to 25° F
- SAE 20W for temperatures 14° to 50° F
- SAE 40W for temperatures 40° to 100° F
- SAE 50W for temperatures 90° to 122° F

Grease:

Belray Molyube EP AC2

www.belray.com

Schaeffer #228 Ultra Supreme

www.schaefferoil.com

Cleaner (Sensitive) HAMMER OPERATION

Fuel: Kerosene

***Lube Oil:**

- Belray # MC1 2 cycle premix (do not premix use directly out of the container as sold)
- Schaeffer #567 Echosheid Biodegradable EP gear oil 50-wt.

***Do not use multi-viscosity lubricants, will void warranty!**

Maintenance Work for Lubricate:	Lubrication Intervals					
	Daily Prior Start Up	Daily after shut down	Every 30 min.	Every Pile	Every 2 hours	When Required
Guide Rails on Starter Guides and Leads	●					
Impact Block (15 to 20 strokes ea. grease nipple with the provided grease gun) Anvil must be closed when greasing.	●		●			
Cylinder End Ring (5 strokes ea. grease nipple with the provided grease gun)	●					
Tripping Device (5 strokes ea. grease nipple with the provided grease gun)	●					
Upper Cylinder: Batter	●			●		

Daily Maintenance

As with every equipment / machinery the Diesel pile hammer does require minor daily inspections to ensure that all bolts and nuts are tightened securely. Since the hammer and it's accessories are subject to excessive shock and vibration while in use, it is possible that loosening of certain bolts can occur. Daily inspection procedures are listed below:

- 1.** Filling of diesel fuel and oil tanks should be performed after machine is put into upright position. Be sure that only clean filtered diesel (#2) fuel is and a good quality high detergent motor oil are added to the tanks. If contamination from dirt or water is suspected, flush tanks thoroughly and refill. Filling the tanks will reduce the possibility of condensation in the fuel and lubrication oil.
- 2.** Check the bolts securing the guide clamps / side guides of the hammer (torque values see Ch. 13)
- 3.** Check nuts securing the fuel pump & lube pump at the lower cylinder (torque values see Ch. 13)
- 4.** Check bolts securing the injection valve at the lower cylinder (torque values see Ch. 13)
- 5.** Check bolts securing the upper and lower cylinder together (torque values see Ch. 13)
- 6.** Check hollow bolts on lubrication points of upper and lower cylinder
- 7.** Check guide gib bolts at the tripping device (torque values see Ch. 13)
- 8.** Lubricate the diesel hammer like described in the table
- 9.** Check for wear at guiding parts
- 10.** Check for wear of rubber ring
- 11.** Check all cables (connected to the hammer , the tripping device, the helmet)
- 12.** Clean the combustion chamber (see Ch. 6)
- 13.** Check hoses and connection

Weekly Maintenance

Weekly inspection of the Diesel pile hammer should include:

- **Remove and inspect the rubber ring** (2 pieces).

This ring prevents the impact block from striking the outer endring / lower cylinder of the hammer while running. This ring also is instrumental in regulating the amount of air volume the machine scavenges, therefore affecting the compression. If damaged, please advise Pileco, Inc.

- **Bolts securing the outer endring to the lower cylinder.** The tightness of this bolts should always be uniform. Running the diesel pile hammer with loose or stretched bolts will result in damage to the other bolts, the endring and the lower cylinder

- **Catch groove and catch piston ring.** When the pile meets strong resistance, piston travel can increase so much that the catch ring may be hit the catch groove in the upper cylinder. If this occurs, immediately reduce fuel injection by lowering the fuel pump setting. Thus shutting off the hammer. Catch groove and catch piston ring must always be in perfect condition, otherwise there is a risk of accident. The catch groove edge can be re machined by taking off the upper endring.

- **Testing the compression.** Only test the compression if the hammer rests on a driven pile, otherwise there is a danger of accident! Hammer should be warm from driving when test is run. Fuel pump is set on "off" (dowel pin at 4 o'clock position). Raise the piston and trip up to the release point and release the piston. There is sufficient compression if the piston does not hit the impact block after the piston is released. Another way to test this is after the hammer is stopped the piston should ride on the air cushion for 6 seconds until it comes to rest. There should be no contact with impact block. If there is less compression the piston rings need to be checked. If a diesel pile hammer is continuously used with worn out piston rings the piston face will be damaged and there is a high risk of piston cracks, because the piston will hit the impact block harder with higher velocity than designed to do so.

Monthly Maintenance

- Empty fuel and lube oil tanks. Remove fuel and lube oil lines. Remove and clean filter nozzles.

Chapter 10

Service and Trouble Shooting



Servicing and Troubleshooting

Problem	Possible Cause	Symptoms	Fault /Remedy
Diesel pile hammer does not start	Compression too low	Impact block drops quickly	Defective or stuck piston rings. Insufficient lubrication at impact head or piston (maintain lubrication intervals as indicated in chapter 9)when lifting the diesel pile hammer
		Strong blowing effect at impact block	
		After dropping and without a fuel supply, piston does bounce only one or two times and then sink slowly	
		Wear grooves in lower cylinder below the exhaust openings	
	Damaged cylinder sleeves		
	Lower cylinder is out of round		
	Low soil resistance	Soft soil, light or pointed or narrow material to be driven, Pile runs	Drop piston several times (cold blows) until there is a sufficient penetration resistance
	Oil grease or water in combustion chamber	Dull sound, when piston impacts the impact block	Clean combustion chamber , and flush fuel tank
		Black smoke (oil or grease in the combustion chamber)	
White smoke (water in the fuel)			

Problem	Possible Cause	Symptoms	Fault /Remedy
Diesel pile hammer does not start	Fuel Problems	Dull sound, when piston hits the impact block	Leaking relief valve (replace relief valve, clean combustion chamber)
		Black smoke (->too much fuel)	- air in fuel pump - Selected setting of fuel control pump is too high
		No smoke or little gray smoke (-> too little fuel)	- Fuel pump is not working properly - Pump element wrong installed in reverse position, supply opening must be at the top position - Sticking pump element, pump lever or guide sleeve or setting - - value of the pump lever has been changed - Defective pump element in fuel pump - Clogged ventilation in diesel tank plug screw - Defective check valve, suction valve, injection valves or shut off valve (replace) - Damaged or clogged fuel lines (replace or clean) - Dirty fuel tank (clean) - Dirty fuel filter
		White or black smoke (-> water or dirt in fuel)	- Water in fuel (clean fuel tank, fuel filter and fuel lines, clean combustion chamber)
	Lack of Lubrication	Impact block gets stuck in cylinder or end ring	- Too little or incorrect lubricant type
	Mechanical	Damage to impact areas of piston or impact block	Machine impact areas
		Stuck or broken piston rings	Replace defective or worn piston rings
Diesel Pile Hammer does not reach required stroke at batter position	Lack of lubrication	Piston stroke is lower compared to vertical pile driving	- Lube pump fault - Grease upper cylinder - Turn the hammer so that the fuel pump is located at the batter down side to compensate piston wear and reaching full stroke of the fuel pump

Problem	Possible Cause	Symptoms	Fault/Remedy
Diesel pile hammer runs irregularly	Mechanical damage	Damaged or deformed upper cylinder / upper cylinder extension	Replace defective parts or have a Pileco authorized repair shop carry out the necessary repair
		Worn cylinder (out of round) or piston is not round	
	Changing soil conditions	Material to be driven penetrates at different rates	Make adjustments during the pile driving by regulating the fuel control pump
	Diesel hammer become too hot (above 600° F /300° C)	Preignition, lower stroke	Check the blow rate (If the blow rate is higher than 150 blows per foot penetration a larger pile hammer must be considered) Choose the right hammer size Check compression Check injection valve and fuel pump (leaking elements or valves can cause insufficient fuel burn)
Diesel pile hammer stops running after a short time	Fuel problems	Clogged fuel filter	
	Diesel hammer becomes too hot - Insufficient combustion	Damaged piston rings, Damaged injection valve, Pump element jams	
Tripping device does not lift the piston	Piston is not latched	Broken dowel pins at trip cam lever	Replace defective or worn parts
		Bent trip cam lever	
		Damaged bearings of trip cam axis	
	Piston is not lifted	Rounded edges at piston lifting groove or pawl	
		Bent or broken leaf spring at tripping device	
		Loose leaf spring bolts	
Tripping device does not lift the diesel	Cam of the tripping device does not grasp below the lifting dogs at the diesel pile hammer	Lack of lubrication at the latch of the tripping device	Lubricate (lubrication intervals maintenance chapter 9)
		Broken torsion spring on the driving pin of the tripping device	Replace broken or worn out part

Guides

Prior to the driving of piles, it will be necessary to check the wear of the...

- guides of the Diesel hammer
- guide gibs of the tripping device
- guides of the pile helmet
- wear strips along the whole lead length.

Lubricating the guide rails of the lead and the starter guides with a MoS₂-containing multipurpose grease extends the lifetime of your equipment.

! WARNING !

Worn guide parts must be replaced immediately! Wear strips at the lead that are too thin must be reinforced immediately! If this is not done, the Diesel pile hammer, the helmet or the tripping device may fall out of the leads! Danger of accident!

It is important to have a well guided hammer and pile helmet: The driving efficiency also depends on how the diesel hammer is in line with the pile. Pileco, Inc. Diesel hammers have the longest possible channel-guiding. This accomplishes a good hammer guiding with a relatively large guiding clearance (which is sometimes necessary if slightly bent or worn out leads are used) Short distance hammer guiding needs a tighter fit to the lead (less guiding clearance)

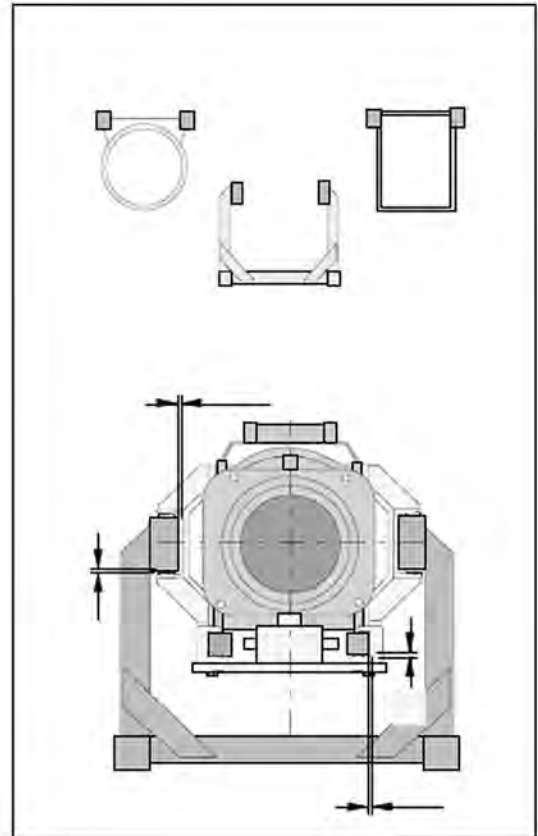

Total Guiding Clearance		
Hammer channel guiding	H1	1/4"
	H2	1/4"
Starter guides	T1	1/4"
	T2	1/4"

Tripping Device

The following items must be checked daily prior to the driving of the piles and when problems are suspected:

- The proper functioning of the trip cam and the lifting mechanism of the tripping device
- The guiding clearance in the guides of the tripping device

Lubricate the tripping device weekly with Molyube 126 EP#2 (5 strokes with a grease gun per grease nipple).

! D A N G E R !

Do not operate the Diesel pile hammer, when the tripping device does not function properly or the overlapping distance between the Diesel pile hammer and the tripping device is too small. Danger of accident!

Worn guide strips must be replaced immediately. When this is not done, the tripping device may jump out of the guide! Danger of accident!

Use only Pileco, Inc. supplied spare parts. We cannot guarantee proper function of the tripping device when other spare parts are used.

Along the whole lead length, the overlap of the latches between the Diesel pile hammer and the tripping device must be at least 9/16" (15 mm) greater than the play of the guide strips

The play of the guide strips must be less than 1/4" or 9/32" (6 mm or 7 mm). If this is not the case, the guide strips must be replaced immediately.

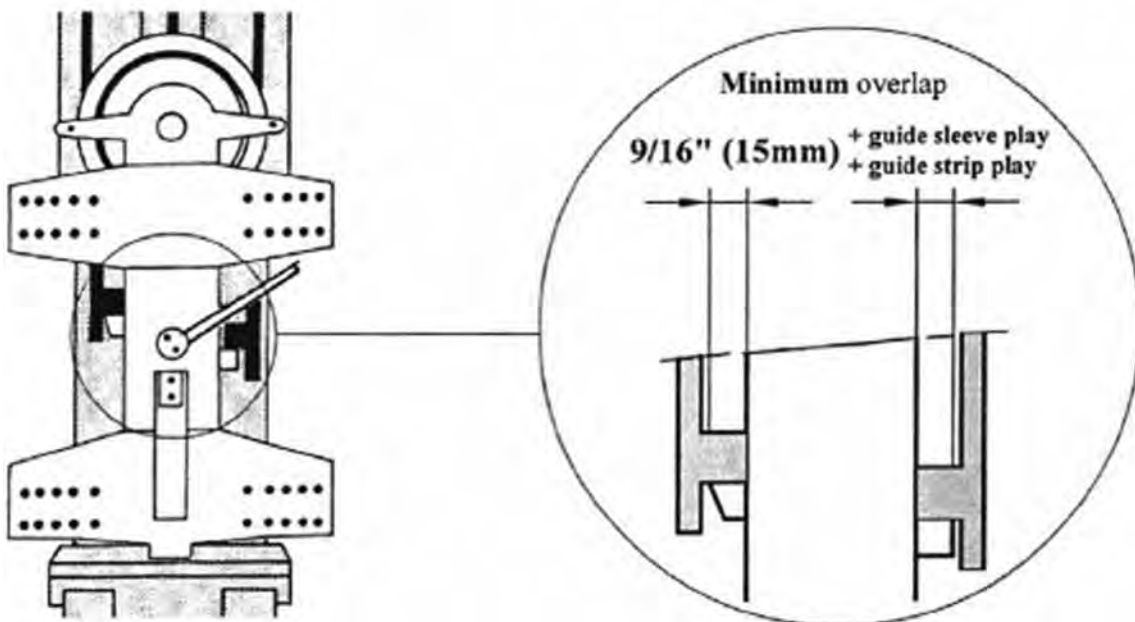

Testing the proper operation

The tripping device is considered inoperative, when one of the following criteria is not met:

1. Lower the tripping device
2. Make sure the trip cam lever (A5) is pushed up when the tripping device impacts the lower support device (9). At the same time, pawl (A4) must swing out fully and must lock.
3. Check the tension and the screw connection of the plate spring.
4. Pull down on the cable at lever (A2). The driving pin (A3) must fully reach its vertical position.
5. Release the cable at lever (A2). The driving pin (A3) must return to fully horizontal position.
6. Check the proper functioning of the rope sheave (if used).
7. Check the tripping device for wear. Particularly the pawl (A4) with lugs and joint bolts as well as the driving pin (A3) and the pawl (A4) should not be rounded or exhibit visible wear.

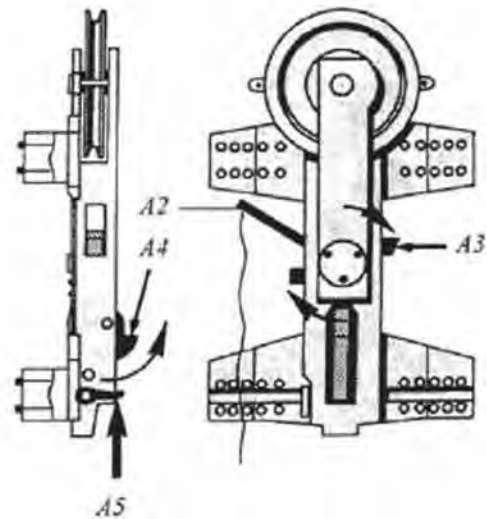
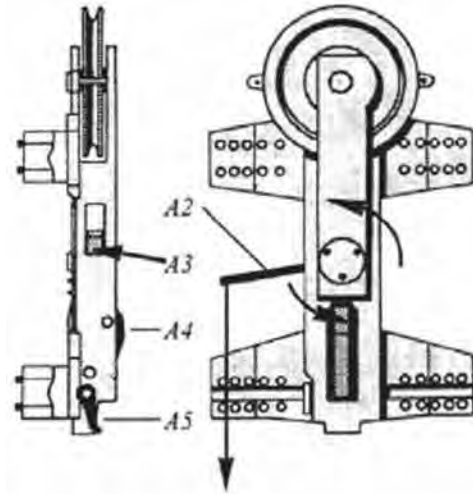

Pumps

Problems with the fuel or lubrication system must be remedied immediately. Such problems pose an increased fire risk and may cause the destruction of the Diesel pile hammer.

Use only Pileco, Inc. supplied spare parts. We cannot guarantee proper function of the pumps when other spare parts are used.. Following the safety instructions indicated at the beginning of chapter 10, “Servicing and Troubleshooting”

Disassembly and cleaning of pumps

The fuel control pump and lubrication pump shall be disassembled and cleaned when necessary (See spare parts list). Remove all paraffin and dirt residues. Make sure all moving parts move easily. Replace worn and defective parts.

The following steps are needed to install the sealing surfaces:

- 1.** Carefully remove any grease from the sealing surfaces as well as from the support surface between the fuel pump and the lower cylinder section. Use a suitable grease remover. Let the grease remover evaporate fully.
- 2.** Use a high performance sealant (Hylomar) or similar (provided in the tool box) for sealing the pumps to the lower cylinder
- 3.** Install the pump.
- 4.** Check for leaks.

Depending on the sealant the sealing surfaces can be separated several times without applying new sealing mass. No foreign material should be left on the sealing surface

Lubricant pump

After each 30 minutes of pile driving work, check that the upper cylinder section is properly supplied with lubricant. The piston and the upper cylinder section must be covered with a thin uniform lubricant film. The following should be checked as well:

- Is the lubricant tank empty?
- Are the lubricant lines clogged or defective? Is the pump lever worn?
- Is the lubricant pump contaminated or defective?

Operate the Diesel pile hammer only after the problems have been remedied. Use a motor oil for the appropriate motor temperature range

Fuel control pump

The control dimension at the fuel control pump is significant for the fuel quantity supplied with each stroke. A dimension that is too long causes an excessive fuel supply to the Diesel pile hammer. Accordingly, there is the risk of the piston jumping into the catch groove. When the control dimension is too small (e.g. due to wear at the pump lever or guide sleeve), the fuel supply will be too low. The diesel pile hammer is thus unable to reach the maximum blow energy. Check the control dimension of the fuel control pump as required. Reset the control dimension when it deviates from the nominal dimension.

- 1.** Set the fuel control pump to setting “4” (full load). To do so, pull on the right control ropes often as required.
- 2.** Measure the control dimension (see pic.next pg.)
- 3.** Compare the measured control dimension with the nominal dimension (see table below).

4. The control dimension must be reset, when the measured control dimension is not within the tolerance. This is achieved by changing the number and thickness of the shims between the pressure section and the mushroom. It is generally sufficient to remove one shim or to use a thinner shim. The pump lever is worn, when it is no longer possible to remove shims. In that case, replace the pump lever and reset the control dimension.

5. Check the injection valve. The pistons in the injection valves must move smoothly and close well. Replace the injection valves when this is not the case.

CAUTION

Never grind the pressure piece or mushroom! The supplied fuel quantity can be measured directly with the test unit for fuel pumps.

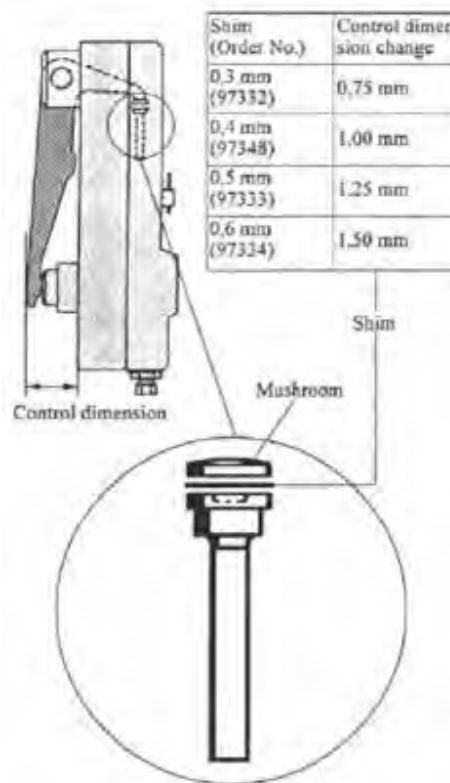

Type	Control dimensions (mm)	Stroke of pump lever(mm)	Supply quantity at full stroke(cm ³ /stroke)	Fuel control pump order #	Injection Valve		Pump Element	
					Qty.	Order #	Ø (mm)	Order #
D6-42	52.5 ^{+0.3}	10.5	1.60	201014	1	104675	14	22903
D8-22	53.5 ^{+0.3}	11.5	1.75	41865	1		14	22903
D12-42	54.0 ^{+0.3}	12.0	2.10	122469	1		15	122470
D19-42	54.0 ^{+0.3}	12.0	3.10	170244	1		19	44027
D25-32	54.5 ^{+0.3}	12.5	3.90	204010	1		20	66522
D30-32			4.70	105172	1		22	66528
D36-32	54.5 ^{+0.3}	12.5	5.65	205010	2	63842	24	64804
D46-32			7.15	105202	2		27	64813
D50-32			7.70	205038	2		28	205039
D62-22	53.5 ^{+0.3}	11.5	8.70	100259	2	104675	31	67218
D70-32	54 ^{+0.3}	12	9.60	207010	2		32	207011
D80-23	55.0 ^{+0.3}	13.0	10.50	66948	4		32	67207
D100-13			12.50	103964	4		35	14655
D125-32	55.5 ^{+0.3}	13.0	15.5	210402	4		39	210414
D138-32	55.0 ^{+0.3}		17.0	210403	4		41	14805
D160-32	55.0 ^{+0.3}	13.0	21.0	220402	4	220404	45	220409
D180-32			23.5	220403	4		48	220410
D225-22	56.3 ^{+0.3}	14.3	17.0 x2	230402	4	230404	39	210414
D250-22	55.6 ^{+0.3}	13.6	18.0 x2	230403	4		41	14805
D280-22	56.4 ^{+0.3}	14.4	19.0 x2	230403	4		41	14805

Filter

Follow the safety instructions indicated at the beginning of this chapter.

When required, clean the filter of the fuel and lubricant tanks as described below:

1. Drain the fuel tank.
2. Pull the fuel line from the filter nozzle.
3. Unscrew the filter nozzle.
4. Clean the filter insert.
5. Screw the filter nozzle back in.
6. Push the fuel line again on the filter nozzle and mount the hose clamp.
7. Fill the fuel tank.
8. Check the filter nozzle for leaks.
9. Clean the filter of the lubricant tank in the same manner.

Grease Nipple

CAUTION

Be careful when working on a hot Diesel pile hammer! Do not touch hot components! Danger of burns!

The grease nipples and lubrication openings must be free of dirt and carbonization and must allow a free flow for the lubricant. Clogged grease nipples must be replaced.

Pump fresh grease again in the grease nipples of the impact block, cylinder end ring and upper cylinder section after shutting off the Diesel pile hammer. This prevents a carbonization of the grease located in the hot grease nipple.

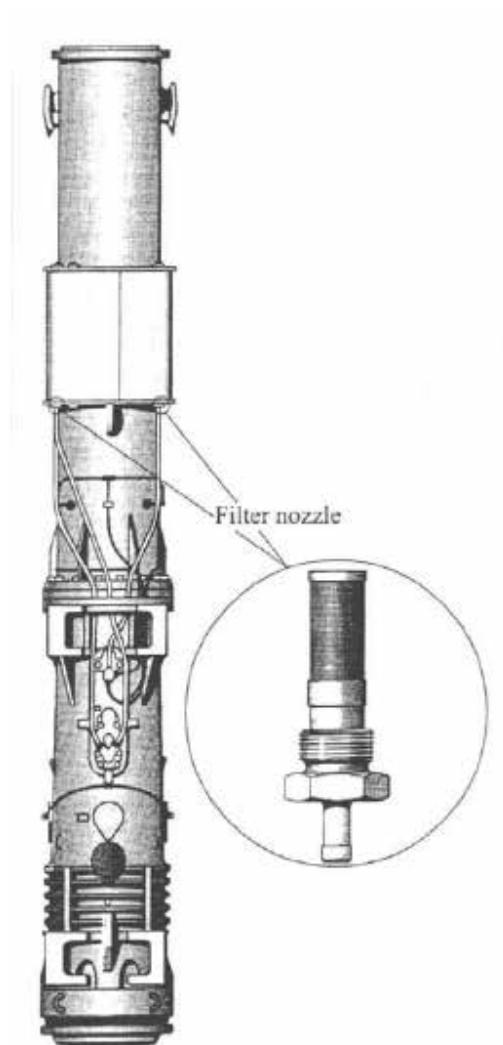

Catch Groove and Piston Catch Ring

The material to be driven penetrates slowly in particularly solid soil or in the case of a very blunt pile. In such a case, the drop height of the impact hammer may continue to increase. You must, in a timely manner, reduce the fuel supply to prevent the piston catch ring from bouncing into the catch groove of the upper cylinder section

The operation of the Diesel pile hammer must be discontinued immediately, when the catch piston ring has bounced into the catch groove of the upper cylinder section. Check the catch groove and the piston catch ring. Both must always be in perfect condition. Machine a damaged catch groove. Replace damaged catch piston rings.

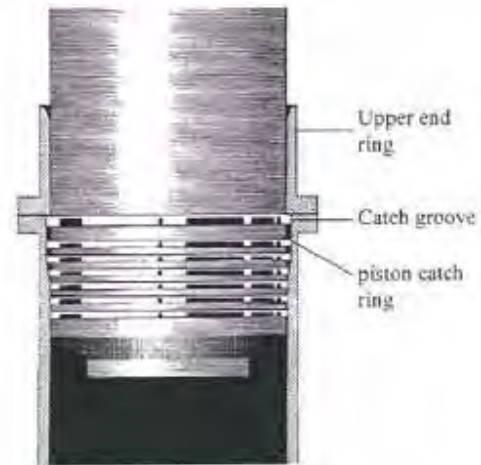

Rubber Rings

Rubber rings are components subject to wear. The service life of damping rings (operating hours to wear) can vary tremendously. The service life of the damping rings is a function of

- the type of pile-driving work,
- the number of strokes per minute,
- the quality of the maintenance work,
- outside effects (weather, dirt)

Worn or damaged damping rings shall be replaced as described below:

Follow the safety instructions indicated at the beginning of this chapter.

- 1.** Let the Diesel pile hammer rest on the impact (19).
- 2.** Remove the impact block safety device, if present impact block (19) is fully extended.
- 3** Lift the Diesel pile hammer until the impact block (19) is fully extended.

Secure the Diesel pile hammer to prevent falling down!

! D A N G E R !

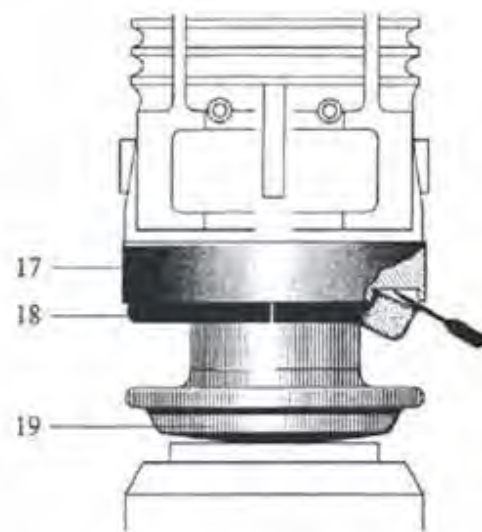

4. Using a screw driver, push the two-piece outer damping ring (18) out of the groove. Keep the loose metal guard for the later installation. Work steps 5 through 19 can be ignored, when it is necessary to replace only the two-piece rubber ring (19).

5. Secure the impact block (19) with wedges against a tilting toward the pile helmet.

6. Attach the supplied installation plates to the two-piece cylinder end ring (17).

7. Screw the installation bolts in the lower cylinder section (15).

8. Unscrew all expansion screws of the cylinder end ring (17). Keep the expansion screws at a safe place.

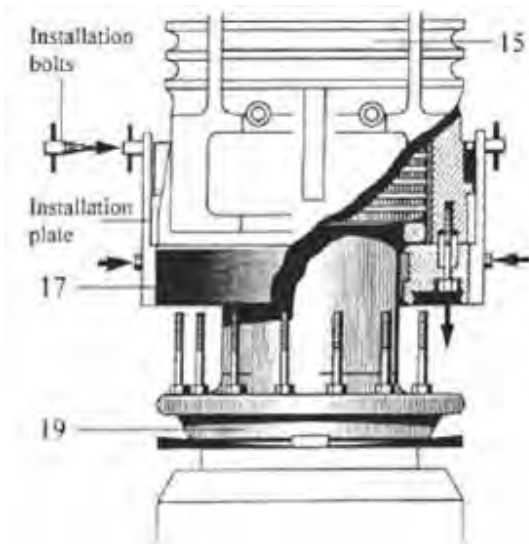

9. Remove the cylinder end ring (17). To do so, screw four expansion screws in the respective threads (See illustration). The width is restricted by the installation bolts.

10. Let the Diesel pile hammer rest on the impact block flange.

11. Unscrew the installation bolts from the lower cylinder section (15).

12. Pull the Diesel pile hammer upward until the inner damping ring (29) is easy to replace. **Secure the Diesel pile hammer from falling down!**

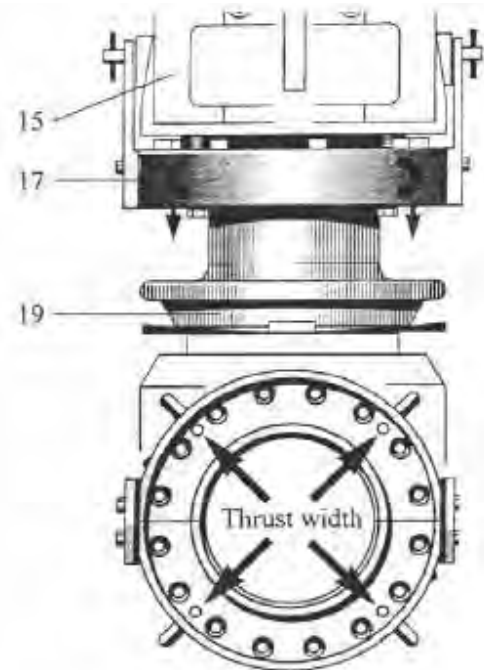

13. Replace the inner damping ring (29).

14. Let the Diesel pile hammer rest on the impact flock range (15).

15. Screw the installation bolts in the lower cylinder section (15).

16. Lift the Diesel pile hammer until the impact block (19) is fully extended.

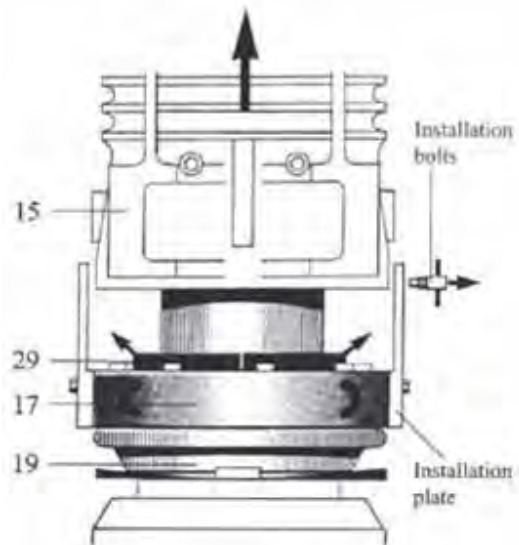

The piston rings remain in the cylinder. Secure the Diesel pile hammer from falling down !

- 17.** Remove the four thrust screws.
- 18.** Screw all expansion screws back in the cylinder end ring (17). Follow the torque data.
- 19.** Remove the installation plates.
- 20.** Place a new two-piece rubber ring (18) of the impact block flange.
- 21.** Place the metal guards indicated in work step 4 on the two-piece rubber ring (18).

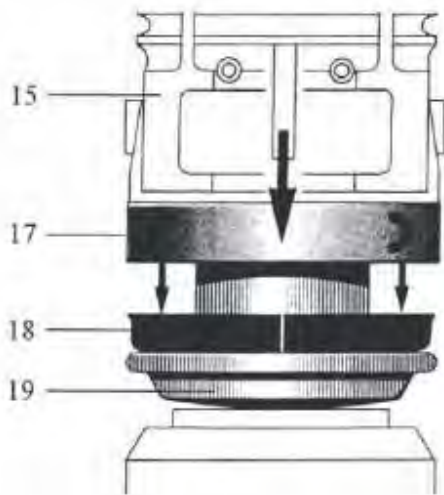

- 22.** Lower the Diesel pile hammer! With its self-weight, the Diesel pile hammer presses the two-piece rubber ring (18) into groove.

Piston and Impact Block Rings

! WARNING !

Worn or damaged piston or impact block rings must be replaced as indicated below.

Follow the safety instructions indicated at the beginning of this chapter.

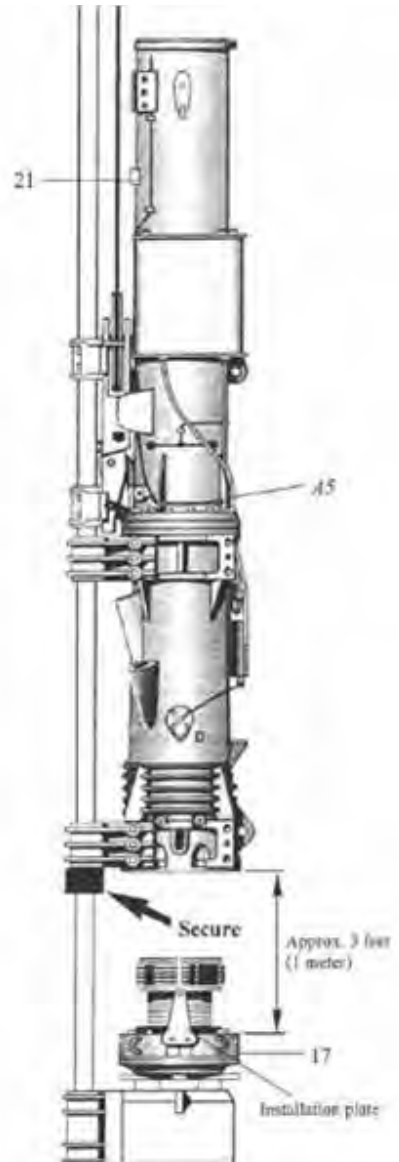

With the Diesel hammers of the types D12 through D100, it will be possible to pull the piston upward and out after disassembling the upper end ring. Work steps 18 and 23. Change accordingly.

1.-11. Proceed the steps 1 through 11, described above

12. Lift the Diesel pile hammer approximately 3 feet (1 meter). The cylinder end ring (17) is kept together with the installation plates and remains on the impact head flange. **Secure the Diesel pile hammer from falling .**

13. Pull the piston (26) upward with the help of the tripping device and stop just prior to reaching the upper stop (21)

! WARNING !

The catch lever (A5) must not touch the upper stop (21). This may cause a release of the piston (26) and it may thus come crashing down. Danger of an accident.

14. Screw the supplied ring screw into the piston (26).

15. Attach a suitable steel cable to the ring screw and the lifting equipment.

16. Lift the piston approximately 2 inches (5 cm).

17. Push the catch lever (A5) down using a pry bar.

18. Lower the piston until all piston rings are easily accessible.

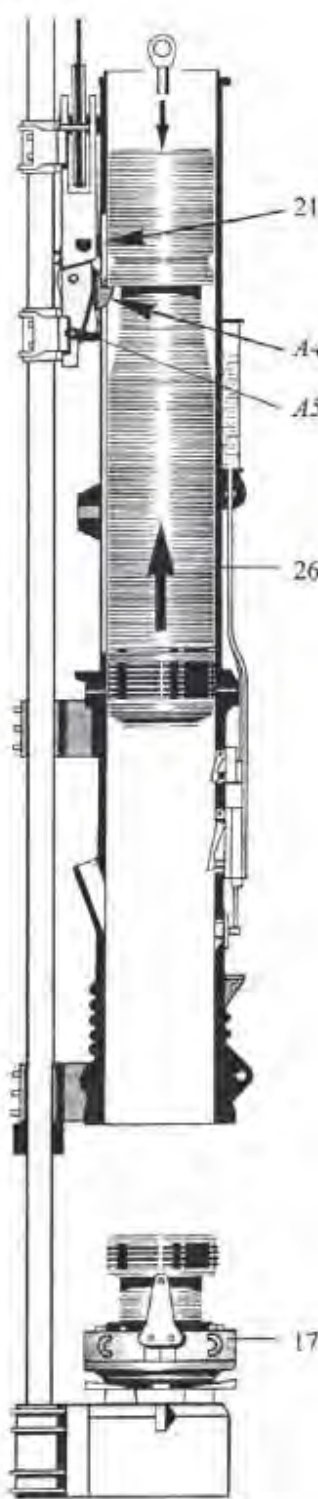

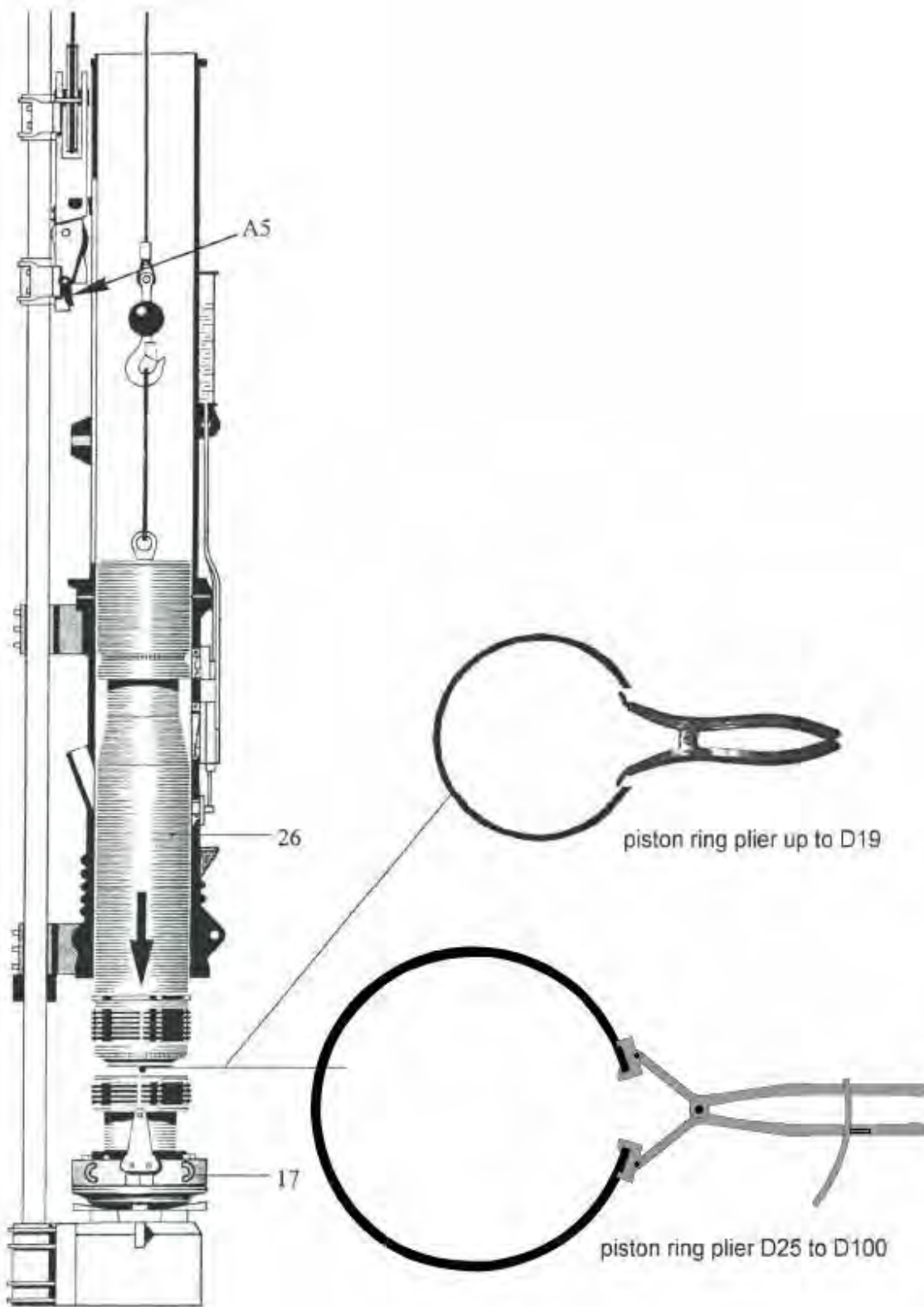

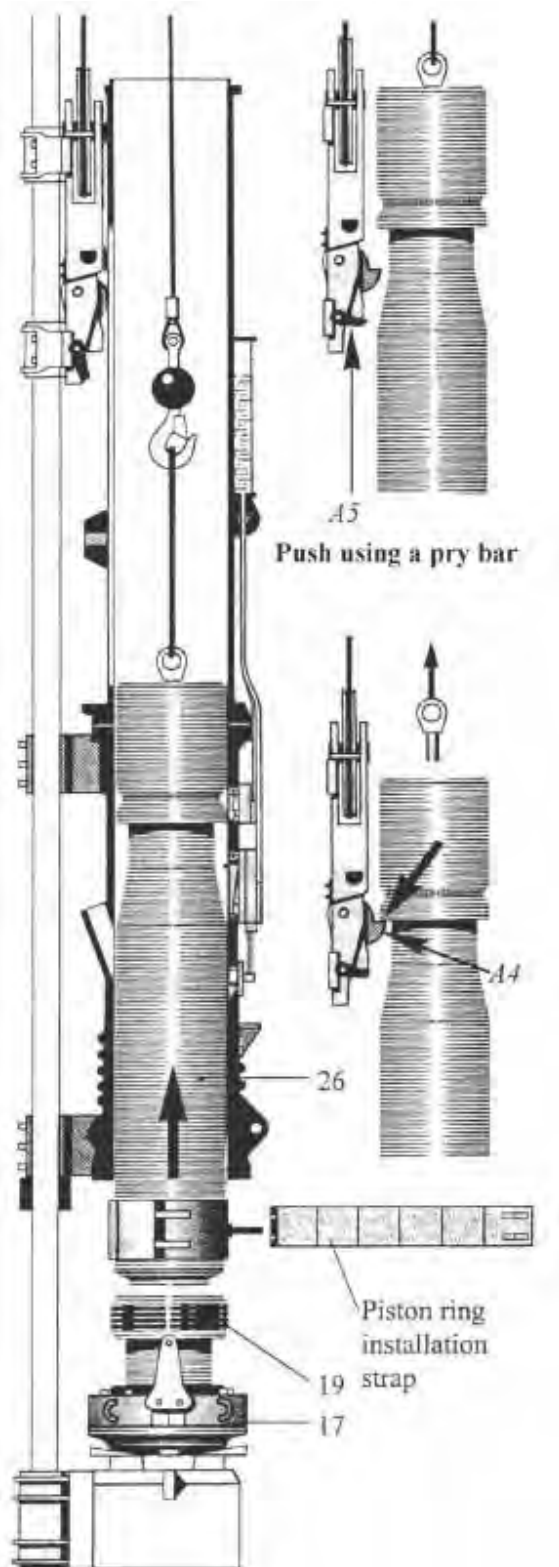

19. Remove the piston and impact block rings using special piston ring installation pliers (included with the tool chest).

20. Carefully clean the piston and impact block ring grooves and apply the special grease.

21. Install the new piston and impact block rings using the special piston ring installation pliers (included in the tool box).

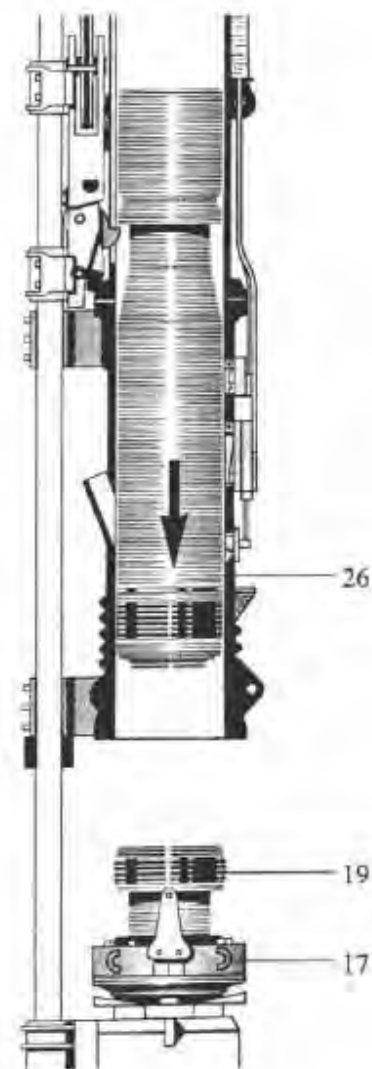

22. Place the supplied piston ring installation band around the piston rings.

23. Carefully pull the piston upward until you are able to push the pawl (A4) into the groove of the piston (26) by pressing the catch lever (A5) upward by hand.

Make sure the piston ring installation strap does not get stuck, when the piston (26) is lifted into the cylinder.

24. Let the piston (26) rest on the pawl (A4).

25. Remove the cable and ring screw from the piston (26).

26. Lower the piston (26) to the lower stop using the tripping device.

27. Place the piston ring installation strap around the impact block (19).

28. Slightly raise the Diesel pile hammer to unlatch the tripping device. Then lower the Diesel pile hammer. Guide the impact block (19) during said phase. Make sure the piston installation strap is not compressed on the cylinder end ring (17) (Stop the downward movement at the appropriate time).

29. Remove the piston ring installation band.

30. Install the inner dampening ring and rubber ring

! WARNING !

The Diesel pile hammers of the types D12 through D100 may be operated only with the upper end ring or the extension of the upper cylinder section in place. Danger of an accident!

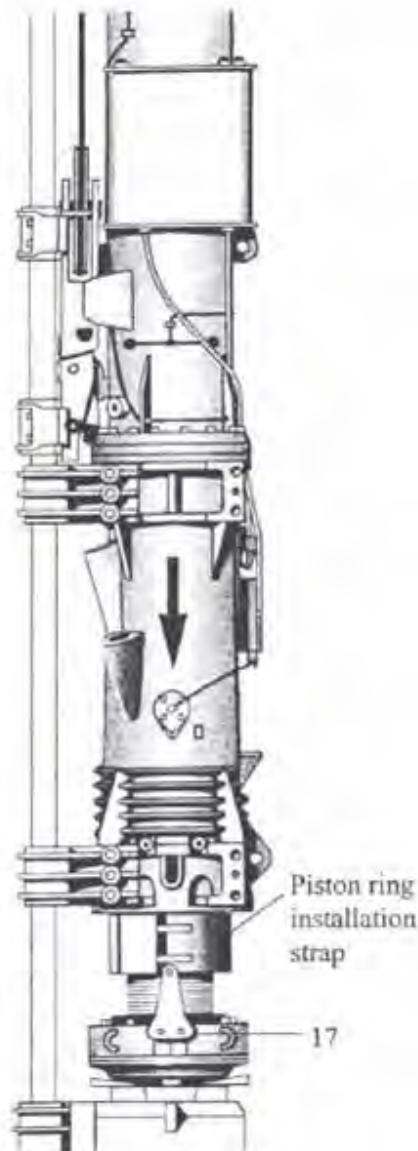

Compression

Starting difficulties may be caused by a compression that is too low. A major decrease in the compression during the pile-driving work will cause the piston to reach lower and lower heights. The Diesel pile hammer will stop in the extreme case.

The compression can be checked as described below:

! WARNING !

You must wear a hard hat, ear plugs, safety goggles, safety gloves, safety boots and suitable work clothes!

- 1.** Place the Diesel pile hammer on a hard pile or a test stand.
- 2.** Set the fuel control pump to setting “0”. To do so, pull the left control rope as often as required.
- 3.** Pull the piston upward until it trips.
- 4.** Watch the piston! Compression is sufficient when the piston bounces after impacting the impact block and comes to rest after at least another three upward and downward movements.

Causes for low compression:

- Defective or stuck piston rings.
- Insufficient lubrication of impact block or piston
- Grooves in the lower cylinder section below the exhaust openings.
- Damaged inner (bearing) ring.
- Damaged cylinder bushings.
- Inside diameter of the lower cylinder is out of round or has grooves (worn out).
- The pile “runs” (soft soil, light, pointed and narrow material to be driven).

Replace the defective components. Lubricate the impact block and piston in accordance with the maintenance schedule.

CAUTION

If defective parts are not replaced and the diesel hammer runs continuously on low compression major damage on the piston can occur :

- The piston profile of the combustion area can deform.
- The piston can break in the ring groove area caused by too high impact speed.

Piston or impact block failure will be examined in every case by Pileco, Inc. to determine a warranty claim

The following steps are helpful in case of a “running” pile (in soft soil)

Starting difficulties: Let the piston drop several times with the fuel supply shutoff (Setting “0”) (cold blows) until the penetration resistance is sufficient for the starting.

Service and Troubleshooting

Chapter 11

Applicable Fuel and Lubrication

Diesel Hammer Fuel and Lubricant Recommendations

***Do not use multi-viscosity lubricants, will void warranty!**

Standard Hammer Operation

Fuel: #2 Diesel

***Lube Oil:**

SAE 5W for temperatures -10° to 10° F

SAE 10W for temperatures 0° to 25° F

SAE 20W for temperatures 14° to 50° F

SAE 40W for temperatures 40° to 100° F

SAE 50W for temperatures 90° to 122° F

Grease:

Belray Molyube EP AC2

www.belray.com

Schaeffer #228 Ultra Supreme

www.schaefferoil.com

The temperature of a diesel pile hammer never should raise over 650° F / 350° C! The lifetime depends on the temperature the diesel pile hammer is used during operation. At high temperature every material ages faster and the strength becomes lower, cracks can occur faster

Cleaner (Sensitive) HAMMER OPERATION

Fuel: Kerosene

***Lube Oil:**

Belray # MC1 2 cycle premix (do not premix use directly out of the container as sold)

Schaeffer #567 Echoshield Biodegradable EP gear oil ISO 150 40+ wt.

Information on Kerosene

- Suitable as a replacement for diesel fuel #2
- Lower smoke emission than diesel fuel
- Same output level than diesel fuel
- Requires high performance 2 cycle engine oil for lubrication
- No conversion of the pump element is required

FUEL	Calorific value MJ/kg	Density at 60° F (15° C) Kg/ dm ³	Viscosity at 68° F (20° C) Kg/ dm ³	Boiling Temperature ° F / ° C
Diesel fuel	42.5	0.82....0.86	2.0....8.0	350...680 / 175...360
Kerosene	43.5	0.77....0.83	4.0	338...500 / 170...260

Please note that most ignition promoters are poisonous and flammable! Follow the respective instructions issued by the manufacturer!

! DANGER !



Chapter 12

Summaries and Calculation Aids



Terms

Rated Energy

The diesel hammers and air / steam hammers rated energy is potential energy, calculated by the ram weight times the drop height. The diesel hammer drop height of the ram weight depends on pile type soil and hammer condition. The maximum energy in the hammer specifications can be reached under optimum driving conditions but it is not necessarily always achievable.

Hammer efficiency

Is the factor or term applied to a hammer’s actual produced energy compared to it’s potential energy. Divide the kinetic energy by the potential energy to determine the hammer efficiency. The diesel hammer efficiency typically averages 0.8 In diesel hammers, energy losses are typically caused by:

- pre-compression, which transfers already some energy into the pile
- friction between ram and cylinder
- impact and inertia losses of the impact block
- pre-ignition, if the hammer is poorly maintained or overheated
- misalignment hammer - helmet – pile

Driving efficiency or transfer efficiency

Is the factor or term applied to the amount of the energy put into the pile (Enthru-energy) compared to the rated energy of the hammer. The samples below show Enthru at the end of driving. Smaller steel normally show a higher transferred energy than larger ones because they are more elastic.

Enthru-energy depends on the type of hammer used, size & type of pile and soil conditions. Smaller steel

pipes show a higher Enthru energy compared to large and much stiffer steel piles. Concrete and timber piles show a lower transferred energy compared to steel piles.

Correlations

The correlation between the number of blows (per minute) and the drop height of the piston is shown in the diagram. The formulas below do not apply for batter piles, only for vertical piles:

$$\text{Drop height (m)} = \frac{4415}{(\text{Number of blows})^2}$$

$$\text{Drop height (ft)} = \frac{14485}{(\text{Number of blows})^2}$$



Pile capacity and Hammer Determination

Before the use of computers became common the pile driving industry worked out many different formulas for pile capacity or hammer determination. All these formulas are based on assumptions and they are not valid in general.

The common procedure today is to perform a WEAP analysis calculation using a computer program.

Based on following customers information a calculation can be done:

- pile size (diameter, length)
- pile type (pipe pile, concrete, timber..)
- required penetration or pile capacity
- soil information (soil layers: depths, type, strength, SPT-N values)

Allowable pile stress during pile driving can properties be calculated by following formulas:

Pile material	Allowable Tension stress	Allowable Compress stress
Steel	$0.9 \times f_y$	$0.9 \times f_y$
Prestressed concrete psi	$F_{PE} + 3 \times f_c^{1/2}$	$0.85 \times f_c - f_{PE}$
Prestressed concrete MPa	$F_{PE} + 0.25 \times f_c^{1/2}$	$0.85 \times f_c - f_{PE}$
Regular reinforced concrete	$0.7 \times f_y / A_c$	$0.85 \times f_c$
timber	$3 \times f_A$	$3 \times f_A$

With following values:

- F_Y – yield strength of reinforcement as a force (kips or kN)
- f_y – yield strength of steel (ksi or MPa)
- A_c – concrete area of the pile
- F_{PE} – effective pre stress
- f_c – concrete strength as stress (MPa or psi)
- f_A – allowable static timber stress

The **ENR-formula** always used in past is a more simple way for an estimation of pile capacity or determination of diesel pile hammer size. Pileco, Inc. provides a slide ruler where the formula practically is “programmed”.

$$R = \frac{2 * E_n}{S + 0.1}$$

- **E_n** – potential energy of the diesel pile hammer in ft.lbs
- **S** – number of blows needed to drive the pile 1 ft into the ground
- **R** – pile capacity in tons

Because the formula only works with the potential hammer energy and the blows per foot (pile penetration) the result is not very accurate and the safety factor is relatively high.

Hammer and Pile Cushion Properties

Cushion material	Elastic modulus WEAP (ksi)	CoR WEAP
Aluminum	10 000	0.8
Aluminum / Micarta	350	0.8
Bongossi wood	290	0.75
Conbest	280	0.8
Micarta	225	0.8
Blue Nylon	175	0.92
Oak parallel	750	0.5
Oak (transverse)	60	0.5
Plywood	30	0.5
Wire rope	150	0.8

The elastic modulus for combined cushion material can be calculated by:

$$E_{EQUIV.} = \frac{E1 \times E2 \times (s1 + s2)}{s1 \times E2 + s2 \times E1}$$

- E1, E2** – elastic modulus
- s1, s2** – thickness of the cushion

Chapter 13

**General Bolt
Torque**

Bolt torque depends on:

- Bolt size, type and grade
- Lubrication (a low friction factor must be considered with MoS2-based grease)

The given bolt torques are based on the 90% of the bolt yield strength

SIZE GRADE metric	Friction factor $\mu = 0.1$ (MoS2)			Friction factor $\mu = 0.14$		
	Torque Nm	Torque ft.lbs.	Pre Tension kN	Torque Nm	Torque ft.lbs.	Pre Tension kN
M8x1.25 8.8	20	15	17.9	25	18	16.5
10.9	30	22	26.3	37	27	24.3
12.9	35	26	30.8	43	32	28.4
M10x1.5 8.8	40	30	28.5	50	40	26.3
10.9	60	40	41.8	70	50	38.7
12.9	70	50	49.0	90	70	45.3
M12x1.75 8.8	70	50	41.5	90	70	38.4
10.9	100	70	61.0	130	100	56.4
12.9	120	90	71.4	150	110	66.0
M14x2 8.8	110	80	56.8	140	100	52.5
10.9	160	120	83.4	200	150	77.2
12.9	190	140	97.6	240	180	90.3
M16x2 8.8	170	130	78.5	220	160	72.7
10.9	250	180	115.3	320	240	106.8
12.9	300	220	134.9	370	270	125.0
M18x2.5 8.8	240	180	95.1	300	220	88.1
10.9	350	260	139.7	430	320	129.3
12.9	410	300	163.5	510	380	151.3
M20x2.5 8.8	340	250	122.5	420	310	113.6
10.9	500	370	180.0	620	460	166.8
12.9	580	430	210.6	720	530	195.2
M22x2.5 8.8	460	340	152.7	570	420	141.7
10.9	670	490	224.3	840	620	208.1
12.9	790	580	262.4	990	730	243.5
M24x3 8.8	580	430	176.5	730	540	163.6
10.9	860	630	259.2	1070	790	240.2
12.9	1000	740	303.3	1250	920	281.1
M27x 3 8.8	850	630	231.6	1070	790	214.9
10.9	1250	920	340.1	1570	1160	315.7
12.9	1460	1080	398.0	1830	1350	369.4
M30x3.5 8.8	1160	860	282.0	1450	1070	261.6
10.9	1700	1250	414.2	2120	1560	384.2
12.9	1990	1470	484.7	2480	1830	449.6
M36x4 8.8	2020	1490	412.2	2530	1870	382.6
10.9	2970	2190	605.4	3710	2740	561.9
12.9	3470	2560	708.5	4350	3210	657.5
M42x4.5 8.8	3230	2380	567.0	4050	2990	526.5
10.9	4750	3500	832.8	5950	4390	773.2
12.9	5560	4100	974.6	6960	5130	904.9

Bolt torque depends on:

- Bolt size, type and grade
- Lubrication (a low friction factor must be considered with MoS2-based grease)

The given bolt torques are based on the 90% of the bolt yield strength

SIZE inch		GRADE	Torque Nm	Torque ft.lbs.	Pre Tension kips	Torque Nm	Torque ft.lbs.	Pre Tension kips
1/4	20	5	8	6	2.0	10	7	1.8
	20	8	12	9	2.8	14	10	2.6
5/16	18	5	17	13	3.3	21	15	3.1
	18	8	24	18	4.7	29	22	4.3
3/8	16	5	30	22	5.0	37	27	4.6
	16	8	43	31	7.0	52	38	6.5
7/16	14	5	48	36	6.9	59	44	6.3
	14	8	68	50	9.7	83	62	8.9
1/2	13	5	74	54	9.2	90	67	8.5
	13	8	104	77	13.0	128	94	12.0
9/16	12	5	106	78	11.9	131	96	11.0
	12	8	150	110	16.8	185	136	15.5
5/8	11	5	146	108	14.8	181	133	13.7
	11	8	207	152	20.9	255	188	19.3
11/16	11	5	200	148	18.6	248	183	17.2
	11	8	283	209	26.2	351	259	24.3
3/4	10	5	260	191	22.1	322	237	20.4
	10	8	366	270	31.1	454	335	28.8
7/8	9	5	418	308	30.6	519	383	28.3
	9	8	590	435	43.2	732	540	40.0
1	8	5	626	462	40.2	778	574	37.2
	8	8	884	652	56.7	1099	810	52.5
1-1/8	7	5	773	570	44.0	960	708	40.8
	7	8	1253	924	71.4	1557	1148	66.1
1-1/4	7	5	1087	802	56.4	1358	1001	52.3
	7	8	1763	1300	91.4	2202	1624	84.7
1-3/8	6	5	1427	1053	66.9	1778	1311	61.9
	6	8	2315	1707	108.4	2883	2126	100.5
1-1/2	6	5	1891	1394	81.9	2364	1744	76.0
	6	8	3066	2261	132.8	3834	2827	123.2
1-5/8	5	5	2347	1731	92.9	2921	2154	86.0
	5	8	3807	2807	150.6	4737	3493	139.5
1-3/4	5	5	2984	2200	110.5	3726	2748	102.4
	5	8	4838	3568	179.1	6043	4456	166.1
2	4.5	5	4482	3305	145.6	5604	4133	135.1
	4.5	8	7267	5359	236.1	9088	6702	219.0



INSPECTION PROTOCOL BOOK

PILECO, Inc. • office (936)494-4200 • 1-800-409-0018 • fax (936)494-4517
www.Pileco.com • 491 Conroe Park W. Dr. • Conroe, TX 77303

04/30/2025

INDEX FOR INSPECTION PROTOCOL FOR PILECO:

DIESEL HAMMER SERVICE RECORD INSPECTION	page 3
DIESEL HAMMER INSPECTION	page 4
PISTON & IMPACT BLOCK INSPECTION	page 5
LOWER CYLINDER INSPECTION	page 6
LOWER CYLINDER ORIGINAL DIMENSION	page 7
PISTON GAP FOR INSPECTION	page 8
ANVIL GAP FOR INSPECTION	page 9
LOWER ENDRING INSPECTION	page 10
FUEL PUMP AND LEVER	page 11
FUEL PUMP ORIGINAL DIMENSION	page 12
PARTS REPLACED DURING SERVICE	page 13-14
INJECTION VALVE TEST	page 15



936.494.4200 office
 936.494.4517 fax
 sales@pileco.com

PILECO INSPECTION PROTOCOL – DIESEL HAMMER SERVICE RECORD

Hammer Model:		Work Order No.:	
Hammer Serial No.:		Date:	
Customer:			
Name of Service Technician:		Signature:	

Condition Upon Arrival

Good _____	Fair _____	Poor _____
Comments:	Comments:	Comments:

Injection Valve Serial #

Lube Pump Serial #

Fuel Pump Serial #

Hydraulic Trip Serial #

Soft Start Serial #

Piston (Ram) Serial #

--	--

Anvil (Impact Block) Serial #

--



936.494.4200 office
 936.494.4517 fax
 sales@pileco.com

PILECO DIESEL HAMMER—INSPECTION PROTOCOL *(use for repair cost estimate and rental equipment)*

General Condition and Procedure

		(Quantity)& Part # of replacement parts
	Steam Clean	
	Inspect Hammer Guiding	
	Inspect Fuel Lines	
	Inspect Oil Delivery Lines	
	Inspect Rubber Ring	
	Inspect Compression Rings	
	Inspect Catch Ring and Groove	
	Inspect Inner Cylinder End Ring	
	Inspect Piston and Impact Block	
	Paint Equipment	

Fuel Pump

		(Quantity)& Part # of replacement parts
	Bench Test output setting 4 output setting 1	
	Inspect regulating Mechanism	
	Inspect Shut-Off and Control Ropes	

Lube Oil Pump

		(Quantity)& Part # of replacement parts
	Check Function	

Starting Device

		(Quantity)& Part # of replacement parts
	Check Pawl	
	Check and Actuate Trip Cam w/ Lever	
	Check Carrier Assembly for Proper Function	
	Inspect Guide Gibs and Connection Hardware	
	Lubricate Carrier Assembly	

PILECO INSPECTION PROTOCOL – PISTON & IMPACT BLOCK

Piston & Impact Block Diameters-Original Manufacturers Dimensions:

type	D8	D12	D19	D25, D30	D36, D46	D50	D62	D70	D80, D100	D125, D138	D160 D180	D225, D250, D280
Piston dia. 1	9.815"	11.771"	12.559"	16.472"	19.606"	19.606"	21.574"	21.574 "	24.704"	28.228"	32.165"	36.850"
Piston dia. 2	9.823"	11.791"	12.578"	16.515"	19.657"	19.657"	21.625"	21.625 "	24.763"	28.307"	32.244"	36.929"
Length of Piston	94.09"	104.13"	128.74"	102.95" 123.23"	106.89" 137.79"	149.69"	149.21"	167.48 "	147.24" 182.83"	173.62" 191.69"	172.63" 194.96"	188.54" 208.66" 227.56"
Length of lifting groove	71.26"	72.44"	70.86"	75.98"	76.38"	76.38"	111.8"	115.23 "	107.87" 114.17"	114.57" 117.76"	122.04" 127.32"	122.04" 126.38" 129.92"
Piston ring width	0.241"	0.278"	0.278"	0.396"	0.396"	0.396"	0.475"	.475"	0.475"	0.514"	0.553"	.629"
Catch ring width	0.477"	0.552"	0.552"	0.790"	0.790"	0.790"	0.790"	.790"	0.947"	1.102"	1.183"	1.259"

Out of round and undersized diameter pistons reduce the diesel hammer performance. Piston replacement is not necessary outside of these tolerances above, but should be considered if out of round values are exceeded

Max. original piston clearance	0.035	0.032	0.036	0.036	0.044	.044	0.047	0.047	0.056	0.055	0.055	0.08
Max. out of round	0.08	0.08	0.08	0.08	0.09	0.09	0.09	0.09	0.10	0.10	0.12	0.20

Note:

- . Out of round pistons worn out piston rings and ring grooves cause excessive cylinder wear and poor hammer performance. Low compression leads to damage of the piston face, broken piston rings or pistons.
- . Piston ring and catch ring grooves should be rebuilt if the ring clearance is larger than 0.02" for small hammers up to the D46 and larger than 0.03" for the large hammers.
- . Welding up the ring grooves for temporary repair is possible with cast iron welding stick from Lincoln Electric "SOFTWELD 99% Ni" welding stick (a very clean area is required)



Measuring Location	Diameter Horizontal	Diameter Vertical
Piston Diameter 1		
Piston Diameter 2		
Anvil Diameter		
Comments: .general wear, scratches, grooves .material buildup .cracks in the ring grooves		
Name of Service Tech:	Signature:	

PILECO INSPECTION PROTOCOL – LOWER CYLINDER
Lower Cylinder Sleeve Diameters – Original Manufactures dimensions:

type	D6 D8	D12	D19	D25 D30	D36 D46	D50	D62	D70	D80 D100	D125 D138	D160 D180	D225, D250, D280
New sleeve Ø	9.846"	11.811"	12.602"	16.535"	19.685"	19.685"	21.656"	21.656"	24.803"	28.346"	32.283"	37.008"
Sleeve length	16.14"	25.98"	26.77"	26.77"	26.77"	26.77"	18.50"	21.65"	25.98"	26.38"	30.39"	43.31"
Resleeving is required if max. wear or shape of cylinder bore exceeds given values below												
Max. wear	0.035"	0.035"	0.035"	0.040"	0.040"	0.040"	0.050"	0.050"	0.050"	0.055"	0.060"	0.065"
Max. out of round	0.008"	0.008"	0.008"	0.008"	0.008"	0.008"	0.008"	0.008"	0.008"	0.008"	0.008"	0.010"

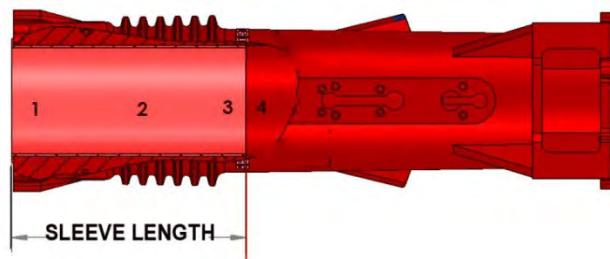
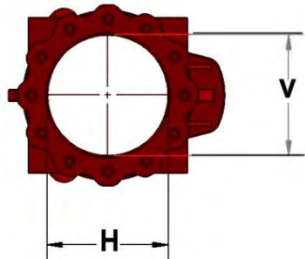

Measuring Location	Diameter Horizontal(H)	Diameter Vertical (V)
Location 1		
Location 2		
Location 3		
Location 4		
Comments: .about wear .scratches/grooves .noticeable steps at sleeve ends .material buildup .cracks .other unusual appearance		
Name of Service Tech:	Signature:	

PILECO INSPECTION PROTOCOL – LOWER CYLINDER ORIGINAL DIMENSION

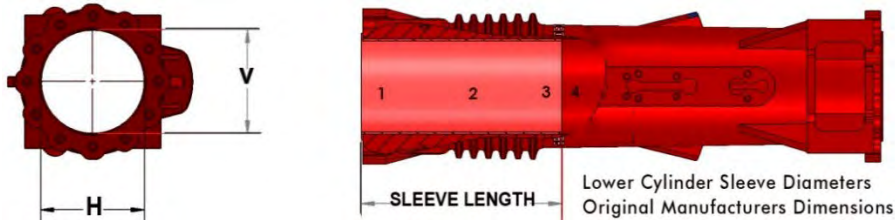

type	D6 D8	D12	D19	D25 D30	D36 D46	D50	D62	D70	D80 D100	D125 D138	D160 D180	D225, D250, D280
New sleeveØ	9.846"	11.811"	12.602"	16.535"	19.685"	19.68"	21.656"	21.656"	24.803"	28.346"	32.283"	37.008"
Sleeve length	16.14"	25.98"	26.77"	26.77"	26.77"	26.77"	18.50"	21.65"	25.98"	26.38"	30.39"	43.31"
Resleeving is required if max. wear or shape of cylinder bore exceeds given values below												
Max. wear	0.035"	0.035"	0.035"	0.040"	0.040"	0.040"	0.050"	0.050"	0.050"	0.055"	0.060"	0.065"
Max. out of round	0.008"	0.008"	0.008"	0.008"	0.008"	0.008"	0.008"	0.080"	0.008"	0.008"	0.008"	0.010"

Piston & Impact Block Diameters –Original Manufacturers Dimensions



type	D8	D12	D19	D25, D30	D36, D46	D50	D62	D70	D80, D100	D125, D138	D160 D180	D225, D250, D280
Piston dia. 1	9.815"	11.77"	12.559"	16.472"	19.606"	19.606"	21.574"	21.574"	24.704"	28.228"	32.165"	36.850"
Piston dia. 2	9.823"	11.79"	12.578"	16.515"	19.657"	19.657"	21.625"	21.625"	24.763"	28.307"	32.244"	36.929"
Length of Piston	94.09"	104.13"	128.74"	102.95" 123.23"	106.89" 137.79"	149.69"	149.21"	167.48"	147.24" 182.83"	173.62" 191.69"	172.63" 194.96"	188.54" 208.66" 227.56"
Length of lifting groove	71.26"	72.44"	70.86"	75.98"	76.38"	76.38"	111.81"	115.23"	107.87" 114.17"	114.57" 117.76"	122.04" 127.32"	122.04" 126.38" 129.92"
Piston ring width	0.241"	0.278"	0.278"	0.396"	0.396"	0.396"	0.475"	0.475"	0.475"	0.514"	0.553"	0.629"
Catch ring width	0.477"	0.552"	0.552"	0.790"	0.790"	0.790"	0.790"	0.790"	0.947"	1.102"	1.183"	1.259"
Out of round and undersized diameter pistons reduce the diesel hammer performance. Piston replacement is not necessary outside of these tolerances above, but should be considered if out of round values are exceeded												
Max. original piston clearance	0.035	0.032	0.036	0.036	0.044	0.044	0.047	0.047	0.056	0.055	0.055	0.08
Max. out of round	0.08	0.08	0.08	0.08	0.09	0.09	0.09	0.09	0.10	0.10	0.12	0.20

Note:

- . Out of round pistons worn out piston rings and ring grooves cause excessive cylinder wear and poor hammer performance. Low compression leads to damage of the piston face, broken piston rings or pistons.
- . Piston ring and catch ring grooves should be rebuilt if the ring clearance is larger than 0.02" for small hammers up to the D46 and larger than 0.03" for the large hammers.
- . Welding up the ring grooves for temporary repair is possible with cast iron welding stick from Lincoln Electric "SOFTWELD 99% Ni" welding stick (a very clean area is required)

PILECO INSPECTION PROTOCOL – PISTON GAP

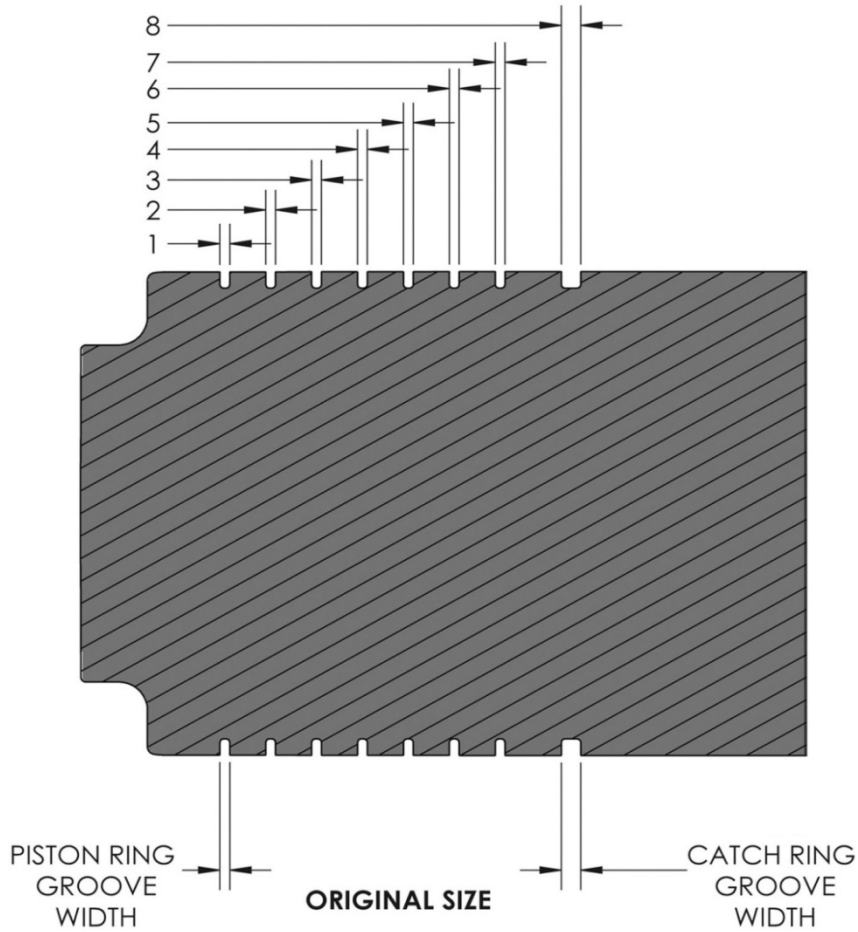

Measure Location:

Piston Ring Groove Width 1	
Piston Ring Groove Width 2	
Piston Ring Groove Width 3	
Piston Ring Groove Width 4	
Piston Ring Groove Width 5	
Piston Ring Groove Width 6	
Piston Ring Groove Width 7	
Piston Ring Groove Width 8	

PILECO INSPECTION PROTOCOL – ANVIL GAP

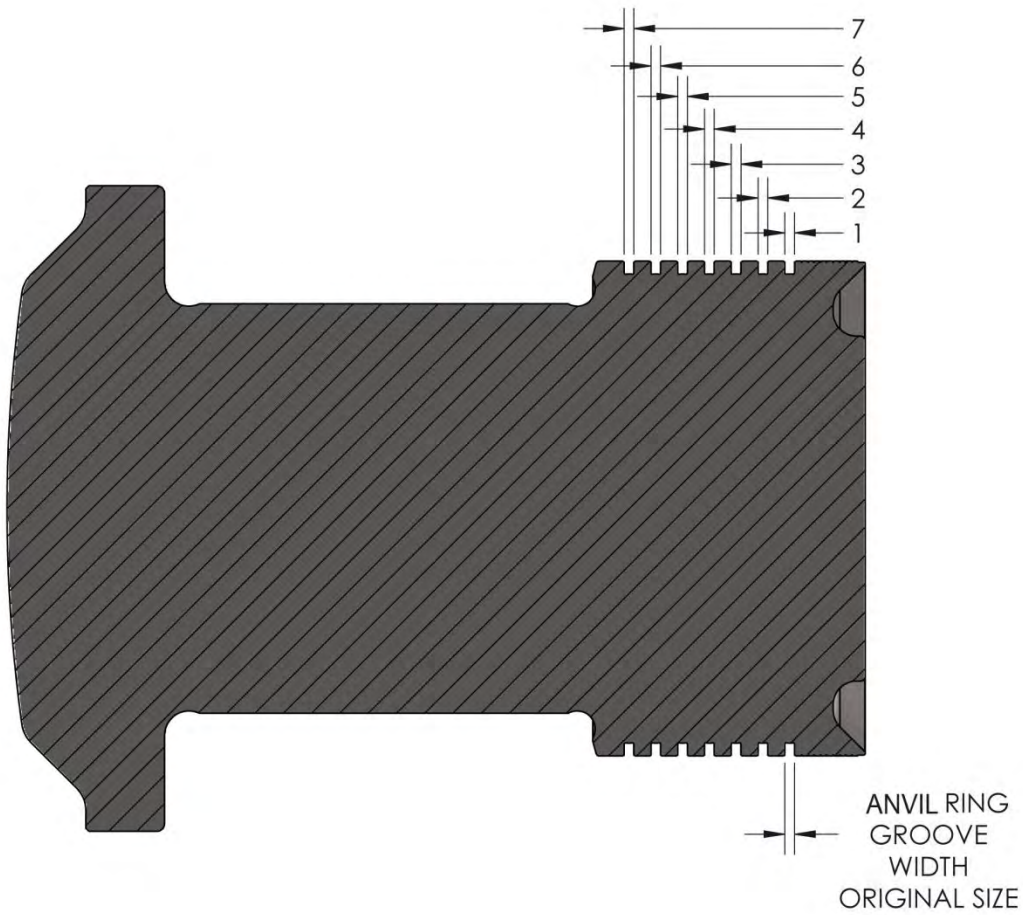

Measure Location:

Anvil Ring Groove Width 1	
Anvil Ring Groove Width 2	
Anvil Ring Groove Width 3	
Anvil Ring Groove Width 4	
Anvil Ring Groove Width 5	
Anvil Ring Groove Width 6	
Anvil Ring Groove Width 7	
Anvil Ring Groove Width 8	

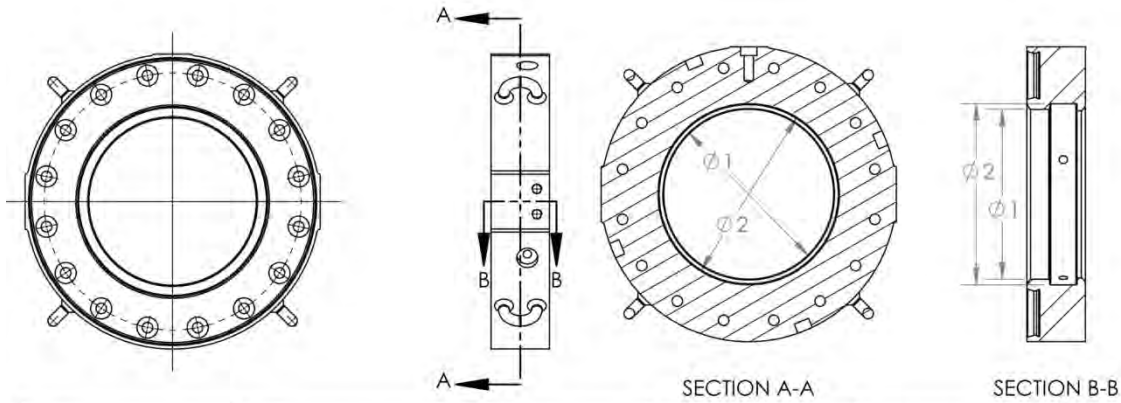
PILECO INSPECTION PROTOCOL – LOWER ENDRING

	Ø 1	Ø 2	ID of Inner Cylinder Endring	Suggest Max. Wear of Ø
D6/D8	200	204	200	1mm
D12	240	244	240.2	1mm
D16/D19	260	264	260.3	1mm
D25/30	330	338	330.3	1mm
D36/D46/D50	390	398	390.5	1.5mm
D62/D70	440	448	440.5	1.5mm
D80/D100	520	528	520.5	1.5mm
D125/D138	600	608	600.6	2mm
D160/D180	690	696	690.6	2mm
D225/D250/ D280	780	790	780.6	2mm

Measuring Location	Diameter Horizontal(H)	Diameter Vertical (V)
Diameter 1		
Diameter 2		
Comments: .about wear .scratches/grooves .material buildup .cracks in ring grooves .other unusual appearance		
Name of Service Tech:	Signature:	

PILECO INSPECTION PROTOCOL – FUEL PUMP & LEVER

Service Order#:	Date:
------------------------	--------------

Fuel Pump Output per Stroke at Setting 4

type	Qty. of Injection valves	Control Dimension		Supply Qty. (cm ³ /stroke)	Pump Element diameter(mm)
		mm	inch		
D6-42	1	52.5 ^{+0.3}	2.067	1.60	14
D8-42	1	53.5 ^{+0.3}	2.106	1.75	14
D12-42	1	54.0 ^{+0.3}	2.126	2.10	15
D16-32	1	54 ^{+0.3}	2.126	2.40	16
D19-42	1	54.6 ^{+0.3}	2.150	3.54	19
D22-32	1	53.5 ^{+0.3}	2.106	3.61	20
D25-32	2	54.5 ^{+0.3}	2.145	3.90	20
D30-32	2	54.5 ^{+0.3}	2.145	4.70	22
D36-32	2	54.0 ^{+0.3}	2.126	5.65	24
D46-32	2	54.5 ^{+0.3}	2.145	7.15	27
D50-32	2	54.7 ^{+0.3}	2.153	7.82	28
D62-22	2	53.5 ^{+0.3}	2.106	8.70	31
D70-32	2	54 ^{+0.3}	2.126	9.60	32
D80-23	4	55.0 ^{+0.3}	2.165	10.50	32
D100-13	4	55.0 ^{+0.3}	2.165	12.50	35
D125-32	4	55.5 ^{+0.3}	2.185	15.50	39
D138-32	4	55.5 ^{+0.3}	2.185	17.50	41
D160-32	4	53.5 ^{+0.3}	2.106	21.00	45
D180-32	4	53.5 ^{+0.3}	2.106	23.50	48
D225-22	4	55 ^{+0.3}	2.165	17.0 x 2	39
D250-22	4	55.6 ^{+0.3}	2.189	18.0 x 2	41
D280-22	4	54 ^{+0.3}	2.125	19.0 x 2	41

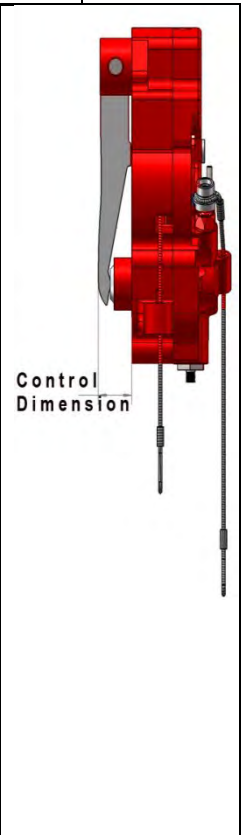

Please Read: Index values listed above are for the control dimension and supply quantity. Adjusting the fuel pump to higher or lower fuel supply may be necessary. This is caused by different driving and hammer conditions. Allowing hammer to achieve or not to exceed the minimum blow count (max. stroke).

Inspection Data

Fuel Pump Serial No.:	Pump Element size:	Fuel Pump Serial No.:	Pump Element size:
Hammer Serial No.:		Date:	
Setting 4	Control Dimension	mm	
	Fuel Output	Cm ³ /20 stroke	
Minimum Hammer Blow Count		1/min	
Paired Injection		Serial#	
Part #	Qty.	Description	
Name of Service Tech.:		Signature:	

PILECO INSPECTION PROTOCOL – FUEL PUMP ORIGINAL DIMENSION

General Conditions & Procedure

Steam clean	Fuel pump	Bench test output setting 4 output setting 1 Inspect regulating mechanism Inspect shut off and control ropes
Inspect hammer guiding		
Inspect fuel lines		
Inspect oil delivery lines		
Inspect rubber ring	Lube pump	Check function
Inspect compression rings	Start. device	Check pawl Check and actuate trip cam with lever Check carrier assembly for proper function Inspect guide gibs and connection hardware Lubricate carrier assembly
Inspect catch ring and groove		
Inspect inner cylinder end ring		
Inspect piston and impact block		
Paint equipment		
piston	- unusual wear, - scratches, grooves - material build up - cracks in the ring grooves	
Lower cylinder	- unusual wear, - scratches / grooves - noticeable steps at sleeve ends - material build up - cracks	

Fuel Pump Standard Settings

type	Qty. of Injection valves	Control Dimension		Supply Qty. (cm ³ /stroke)	Pump Element diameter(mm)
		mm	inch		
D6-42	1	52.5 ^{+0.3}	2.067	1.60	14
D8-42	1	53.5 ^{+0.3}	2.106	1.75	14
D12-42	1	54.0 ^{+0.3}	2.126	2.10	15
D16-32	1	54 ^{+0.3}	2.126	2.40	16
D19-42	1	54.6 ^{+0.3}	2.150	3.54	19
D22-32	1	53.5 ^{+0.3}	2.106	3.61	20
D25-32	2	54.5 ^{+0.3}	2.145	3.90	20
D30-32	2	54.5 ^{+0.3}	2.145	4.70	22
D36-32	2	54.0 ^{+0.3}	2.126	5.65	24
D46-32	2	54.5 ^{+0.3}	2.145	7.15	27
D50-32	2	54.7 ^{+0.3}	2.153	7.82	28
D62-22	2	53.5 ^{+0.3}	2.106	8.70	31
D70-32	2	54 ^{+0.3}	2.126	9.60	32
D80-23	4	55.0 ^{+0.3}	2.165	10.50	32
D100-13	4	55.0 ^{+0.3}	2.165	12.50	35
D125-32	4	55.5 ^{+0.3}	2.185	15.50	39
D138-32	4	55.5 ^{+0.3}	2.185	17.50	41
D160-32	4	53.5 ^{+0.3}	2.106	21.00	45
D180-32	4	53.5 ^{+0.3}	2.106	23.50	48
D225-22	4	55 ^{+0.3}	2.165	17.0 x 2	39
D250-22	4	55.6 ^{+0.3}	2.189	18.0 x 2	41
D280-22	4	54 ^{+0.3}	2.125	19.0 x 2	41

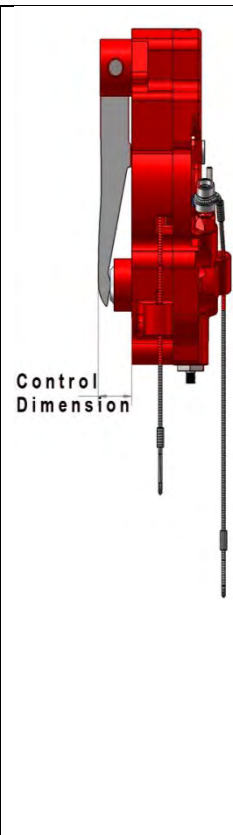

PILECO INSPECTION PROTOCOL – INJECTION VALVE

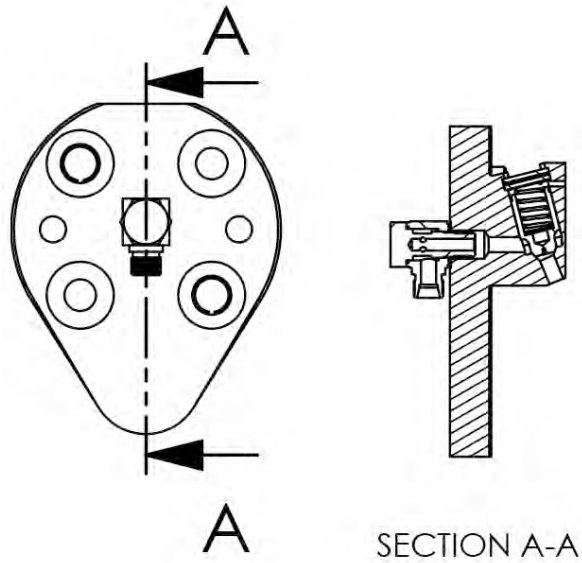

SETTINGS

SEAL PRESSURE 0.09 ~ 0.1 MPA
 OPENING PRESSURE 0.12 ~ 0.14 MPA

Injection Valve Pressure _____ MPA	
Degree of Plate _____	
Name of Service Tech.:	Signature:
SN#:	Date: